



# Terex Fuchs Professional Solutions for Port Handling

Ben Peng, Terex Deutschland GmbH

29th of September 2022

 **FUCHS**<sup>®</sup>  
A TEREX BRAND

# Agenda

- Fuchs a TEREX brand
- Dealer Network in the Region
- Fuchs Value Added Services
- Testimonials
- Outlook

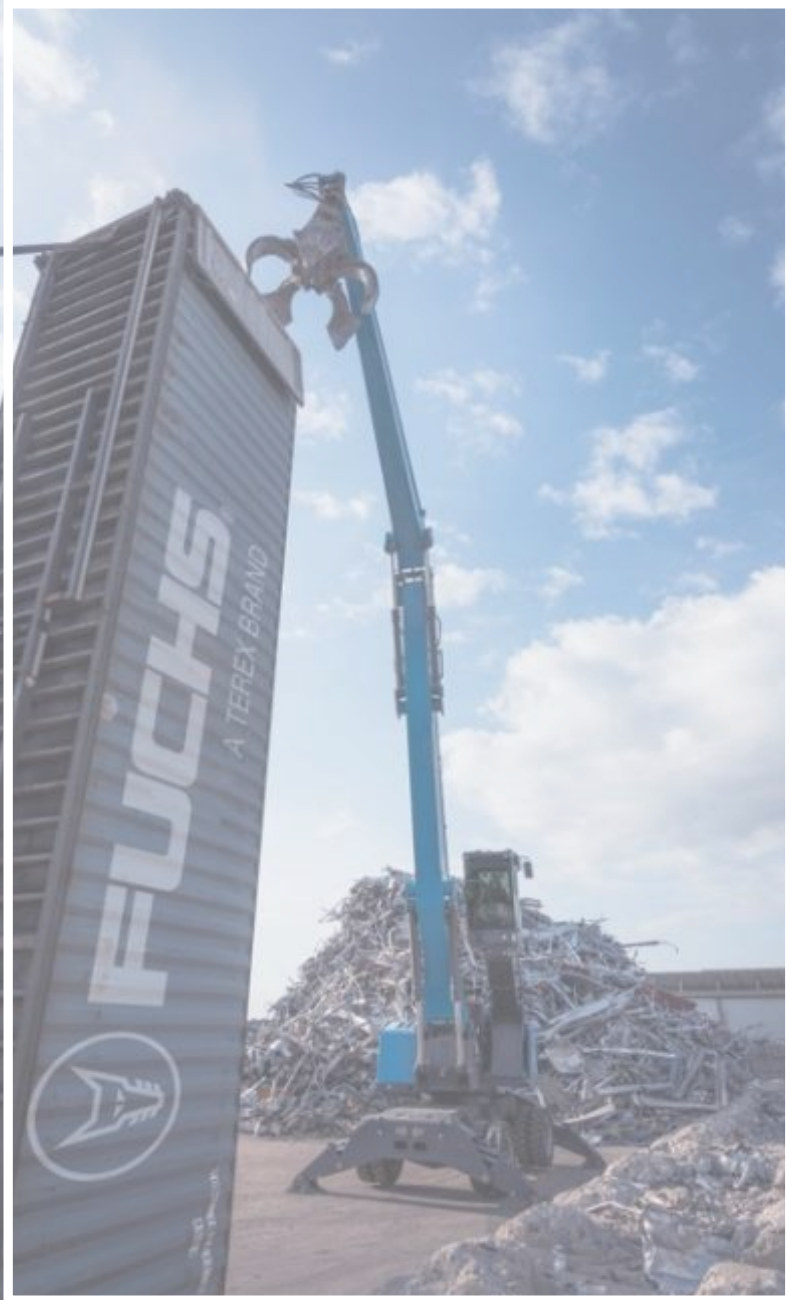

# Agenda

- Fuchs a TEREX brand
- Dealer Network in the Region
- Fuchs Value Added Services
- Testimonials
- Outlook



# TEREX Corporation

## Business units and brands

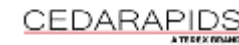

# TEREX Corporation

## Business units and brands



**TEREX**®

EXECUTE. INNOVATE. GROW.





# Fuchs a TEREX brand





## Global Footprint

Bad Schönborn, Baden- Württemberg  
Germany    **HQ**



Louisville, KY  
USA  

Changzhou, Jiangsu  
China  

-  Production for global market & HQ
-  Production for domestic market
-  Service Hub
-  Sales Office

# Agenda

- Fuchs a TEREX brand
- **Dealer Network in the Region**
- Fuchs Value Added Services
- Testimonials
- Outlook



# Fuchs operations in Asean Member Countries

## ASEAN Member Countries









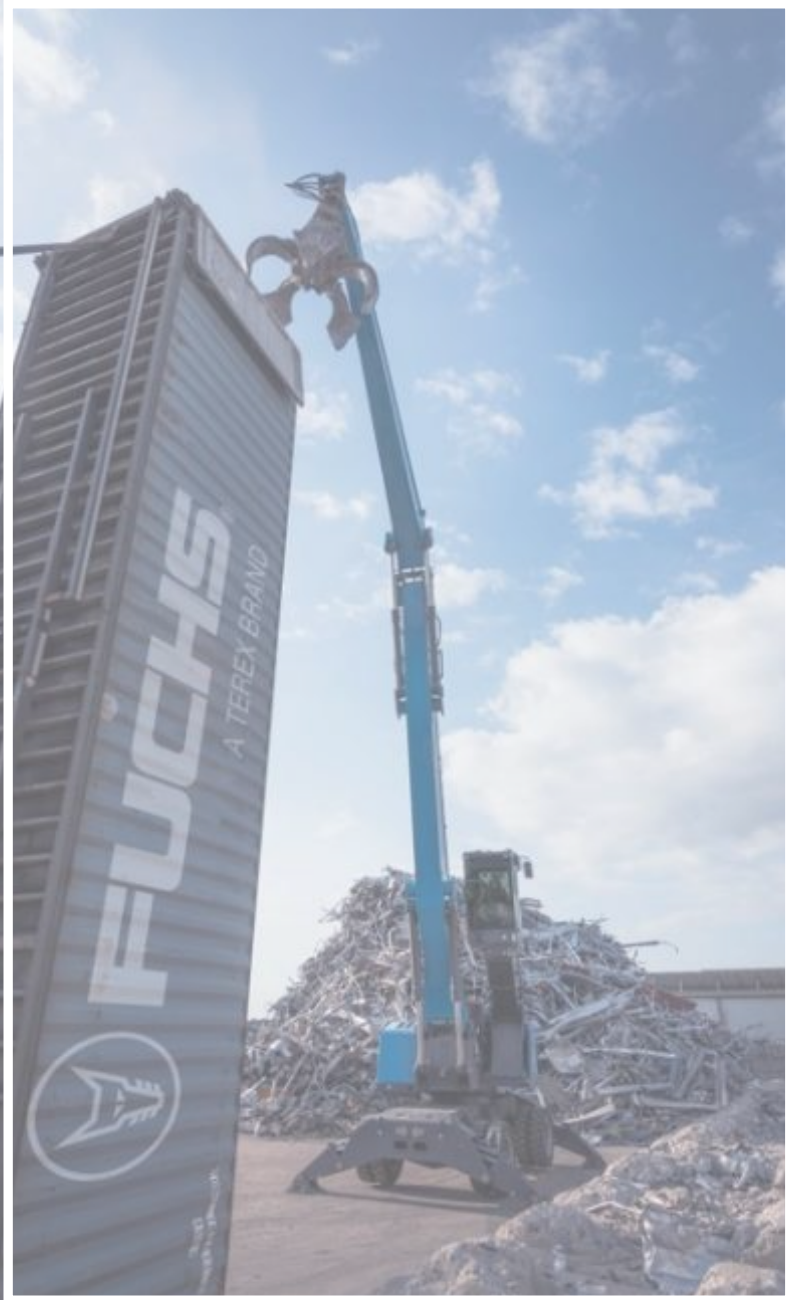









# Agenda













- Fuchs a TEREX brand
- Dealer Network in the Region
- **Fuchs Value Added Services**
- Testimonials
- Outlook



# Product Portfolio – MHL



									
	<b>MHL 310</b>	<b>MHL 320</b>	<b>MHL 331</b>	<b>MHL 335</b>	<b>MHL 340</b>	<b>MHL 345</b>	<b>MHL 350</b>	<b>MHL 355</b>	<b>MHL 360</b>
	85 kW	95 kW	115 kW	115 kW	129 kW	129 kW	160 kW	160 kW	190 kW
	■	EDG	EDG	EDG	128 kW	128 kW	148 kW	148 kW	186 kW
	75 kW	75 kW	90 kW	90 kW	110 kW	110 kW	132 kW	132 kW	160 kW
	17,1 t	21,0 t	24,2 t	25,5 t	30,6 t	31,2 t	35,5 t	40,0 t	48,8 t
	9,0 m	10,4 m	12,0 m	12,0 m	13,7 m	13,7 m	16,0 m	16,0 m	18,0 m

								
	<b>MHL 365</b>	<b>MHL 370</b>	<b>MHL 375</b>	<b>MHL 375 HD</b>	<b>MHL 380</b>	<b>MHL 390</b>	<b>MHL 360 PYLON (0,8 m)</b>	<b>MHL 365 PYLON (1,4 m)</b>
	190 kW	230 kW	245 kW	245 kW	273 kW	300 kW	190 kW	190 kW
	186 kW	■	■	■	273 kW	273 kW	186 kW	186 kW
	160 kW	200 kW	200 kW	200 kW	250 kW	250 kW	160 kW	160 kW
	51,8 t	52,0 t	66,0 t	71,0 t	70,0 t	87,0 t	50,1 t	55,5 t
	15,0 m	18,0 m	20,0 m	22,0 m	22,0 m	24,5 m	18,0 m	18,0 m



All Models are also available with Electric drive

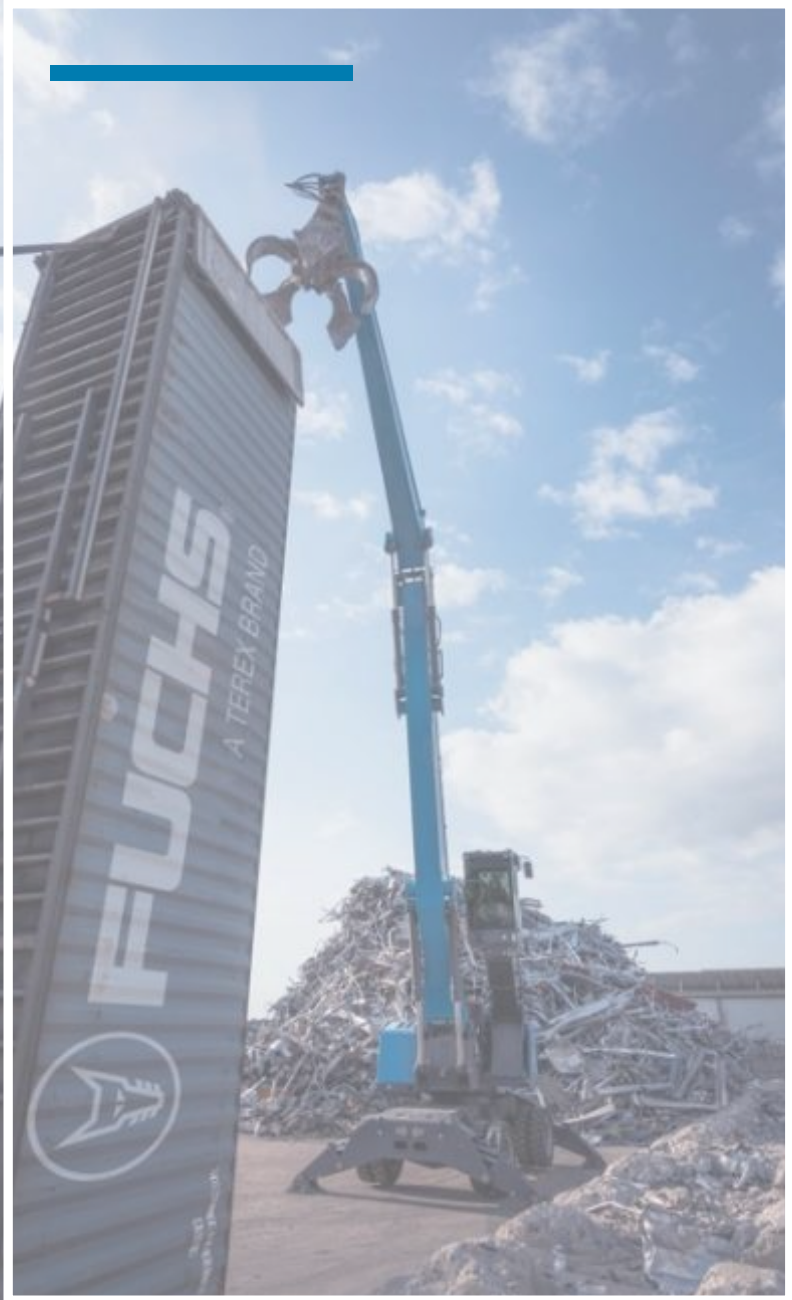

# Product Portfolio – RHL (Track)



**RHL 320      RHL 331      RHL 340      RHL 350      RHL 360**

	95 kW	115 kW	129 kW	160 kW	190 kW
	EDG	EDG	128 kW	148 kW	186 kW
	75 kW	90 kW	110 kW	132 kW	160 kW
	28,5 t	29,0 t	38,0 t	43,0 t	54,0 t
	10,4 m	12,0 m	13,7 m	16,0 m	18,0 m



**RHL 370      RHL 375      RHL 390      RHL 390 XL      RHL 390 GANTRY**

	230 kW	245 kW	300 kW	300 kW	300 kW
	■	■	273 kW	273 kW	273 kW
	200 kW	200 kW	250 kW	250 kW	250 kW
	55,0 t	75,0 t	85,0 t	88,4 t	110,0 t
	18,0 m	22,0 m	24,5 m	24,5 m	24,5 m



All Models are also available with Electric drive

# Application

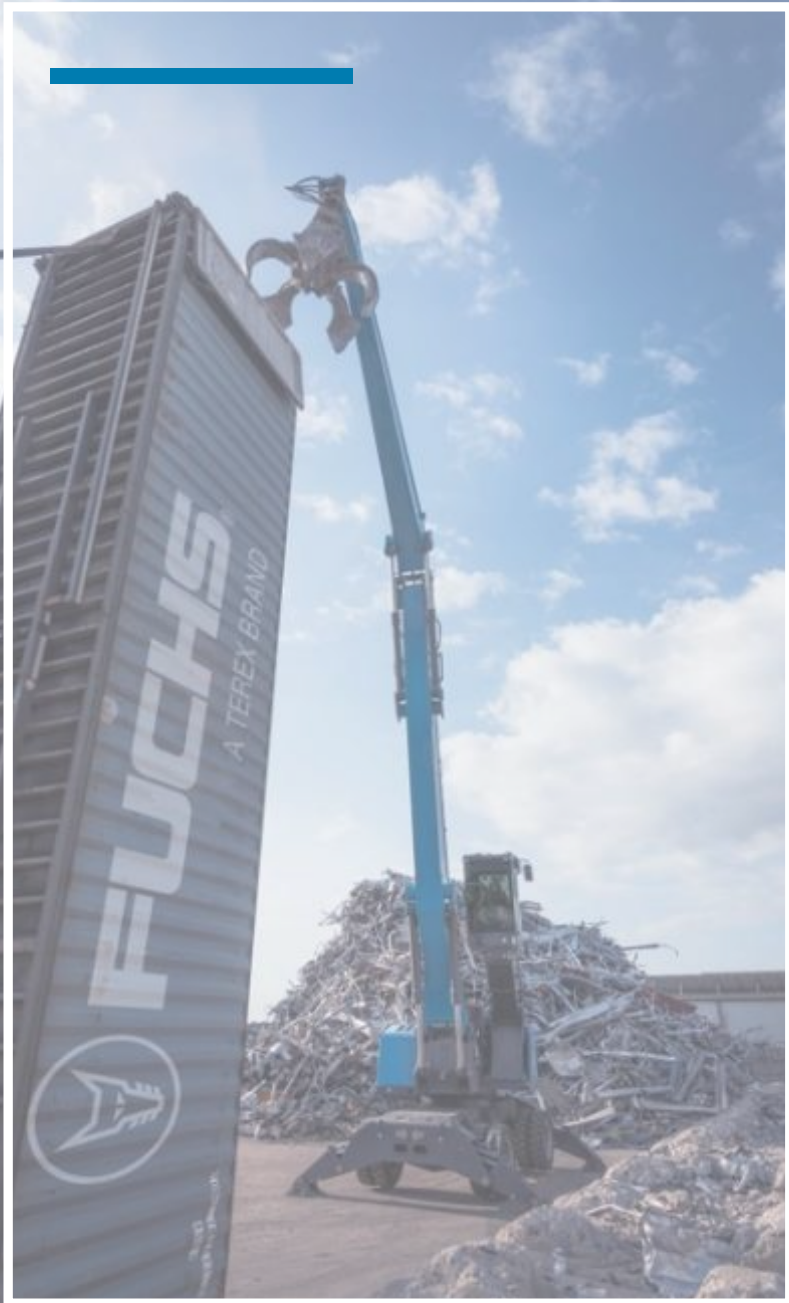

✓ WASTE

# Application



> SCRAP

# Application



> PORT

# Fuchs Connect Portal



## Advantages:

- ✓ New Layout incl. Dashboard (Widgets)
- ✓ New functions - maintenance and Assignments
- ✓ Improved Reporting
- ✓ Open for new features

# Fuchs Connect Portal



Search

MG My Account

- Dashboard
- Machines**
- Maintenance
- Events
- Assignments
- Reports
- Administration
- Links
- Instructions

## Machines

MACHINES / MHL360F / MHL360F #5738

Dashboard configuration  
Machine Dashboard

- EDIT
- MANAGE
- REFRESH



REALTIME SINCE 30.08.2022 08:08

### MHL360F #5738

DETAILS

LOCATION

#### Machine info

Organization: [C] TSR Lünen [OU]  
Model: MHL360F  
Serial number: 5738

20 °C

#### MACHINE MAP



MACHINE DATA

EVENTS

DTC'S

CONSUMPTION REPORT

USAGE REPORT

SIGNALS

IGNITION HOURS

3517 h

WORKING HOURS

3330 h

MACHINE STATUS



MACHINE WORKING

SOFTWAREUPDATE STATUS



HYDRAULIC WORKING HOURS

2078 h

DRIVING HOURS

172 h

FILLING LEVELS

diesel filling level

49 %

DEF level

92 %

Lab mode is currently active  
pro 111.047





# Fuchs Connect Portal



Search

MG My Account ▼

- ☰ Dashboard
- ▶ **Machines**
- ✂ Maintenance
- 📅 Events
- 📄 Assignments
- 📊 Reports ▼
- ⚙ Administration ▼
- 🔗 Links ▼
- ℹ Instructions ▼

## Machines

MACHINES / MHL360E / MHL360E #5738

Dashboard configuration  
Machine Dashboard ▼

EDIT MANAGE REFRESH



Organization: [TEL TSK LUDWIG](#)

Model: MHL360E

Serial number: 5738

☁ 20 °C ✂ 📍 📄



MACHINE DATA

EVENTS

DTC'S

**CONSUMPTION REPORT**

USAGE REPORT

SIGNALS

### WORK ECO MODE CONSUMPTION

LAST 1 WEEK DELTA



● Delta: Load fuel consumption ECO-Mode

### WORK POWER MODE CONSUMPTION

LAST 1 WEEK DELTA

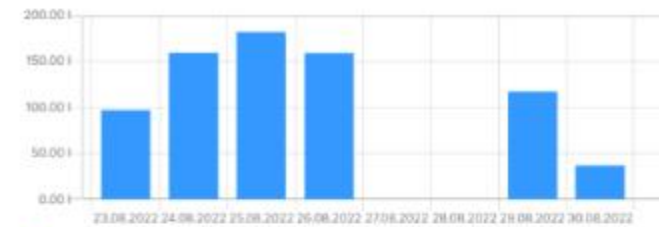

● Delta: Load fuel consumption Power-Mode

### WORK FUEL CONSUMPTION

LAST 1 WEEK DELTA

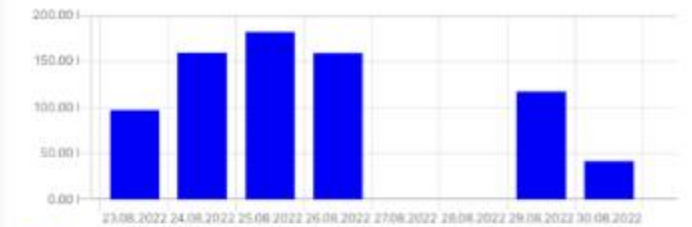

● Delta: Load fuel consumption

### IDLE FUEL CONSUMPTION

LAST 1 WEEK DELTA



### TOTAL FUEL CONSUMPTION

LAST 1 WEEK DELTA

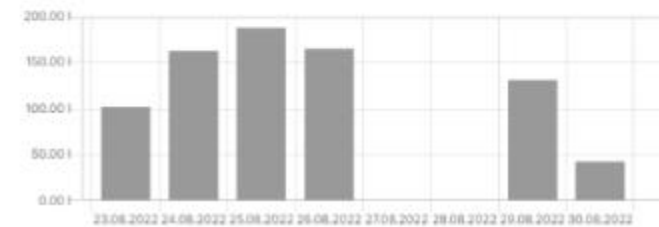

### AVERAGE FUEL CONSUMPTION

LAST 1 WEEK MAXIMUM

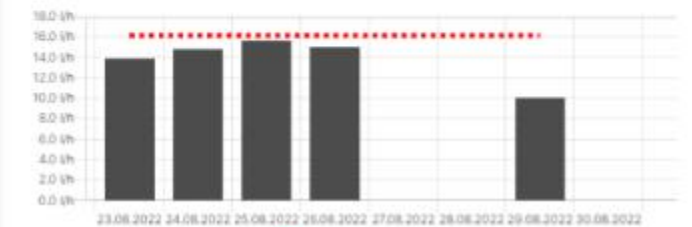

Lab mode is currently active  
pid 111847

# Fuchs Connect Portal



Search



Mv Account



- Dashboard
- Machines
- Maintenance**
- Events
- Assignments
- Reports
- Administration
- Links
- Instructions

## Maintenance Tasks

MHL360F #5738



### Maintenance at 3000 total Operating Hours

COMPLETED

Completed at:

3083 h

Target:

3000 h

Machine: MHL360F #5738

Model: MHL360F

Organization: [C] TSR Lünen [OU]

Created 29.06.2022 02:43, modified 15.07.2022 02:43



### Maintenance at 2500 total Operating Hours

SKIPPED

Skipped at:

2954 h

Target:

2500 h

Machine: MHL360F #5738

Model: MHL360F

Organization: [C] TSR Lünen [OU]

Created 03.06.2022 02:43, modified 29.06.2022 02:43



### Maintenance at 2000 total Operating Hours

COMPLETED

Completed at:

2362 h

Target:

2000 h

Machine: MHL360F #5738

Model: MHL360F

Organization: [C] TSR Lünen [OU]

Created 18.02.2022 01:53, modified 18.02.2022 17:01

## Maintenance at 3000 total Operating Hours

COMPLETED

### operating hours

Last known value when completed:

3083 h

Target:

3000 h

Assigned to:



User



**MHL360F #5738**

Model: MHL360F

Organization: [C] TSR Lünen [OU]

### Description

Operating Hours: 2954

#### Activities:

- 500h Clean diesel engine radiator
- 500h Perform standstill regeneration (in advance of engine oil change)
- 1000h Charge air cooler inlet area; drain lubricating oil, condensate
- 3000h Grab hydraulic oil filter (optional)

#### Replace:

- 500h Engine oil
- 500h Engine oil filter
- 500h Filter insert for AdBlue / DEF EU (Stage IV+V / EPA Tier 4f)
- 500h Manual transmission oil
- 1000h Fuel pre-filter
- 1000h Fuel filters
- 1000h main air filter cartridge and safety cartridge
- 1000h hydraulic oil tank ventilation filter
- 3000h Hydraulic oil
- 3000h Return filter insert

#### Check:

1000h Inspect engine oil



# Fuchs Connect Portal



MG My Account ▼

- Dashboard
- Machines
- Maintenance
- Events**
- Assignments
- Reports
- Administration
- Links
- Instructions

## Events

MHL360F #5738 ×

**Refuel** SEVERITY 30

Event key: event.common.consumables.fuel.refill  
Occurred: 26.08.2022 13:45  
Machine: MHL360F #5738

**DEF Refill** SEVERITY 30

Event key: event.common.consumables.def.refill  
Occurred: 26.08.2022 13:30  
Machine: MHL360F #5738

**Refuel** SEVERITY 40

Event key: event.common.consumables.fuel.refill  
Occurred: 24.08.2022 13:45  
Machine: MHL360F #5738

**Refuel** SEVERITY 30

Event key: event.common.consumables.fuel.refill  
Occurred: 22.08.2022 13:35  
Machine: MHL360F #5738

**DEF Refill** SEVERITY 30

Event key: event.common.consumables.def.refill  
Occurred: 22.08.2022 13:20  
Machine: MHL360F #5738

## Refuel

SEVERITY 30

Event key: event.common.consumables.fuel.refill  
Occurred: 26.08.2022 13:45  
Machine: [MHL360F #5738](#)

PROPERTIES	TIMESERIES	MAP
<b>Key</b>	<b>Value</b>	
Start	26.08.2022 13:35	
End	26.08.2022 13:45	
Level Before	145 l	
Level After	580 l	
Level Difference	435 l	
Operating Hours	3310 h	



# Fuchs Connect Reports

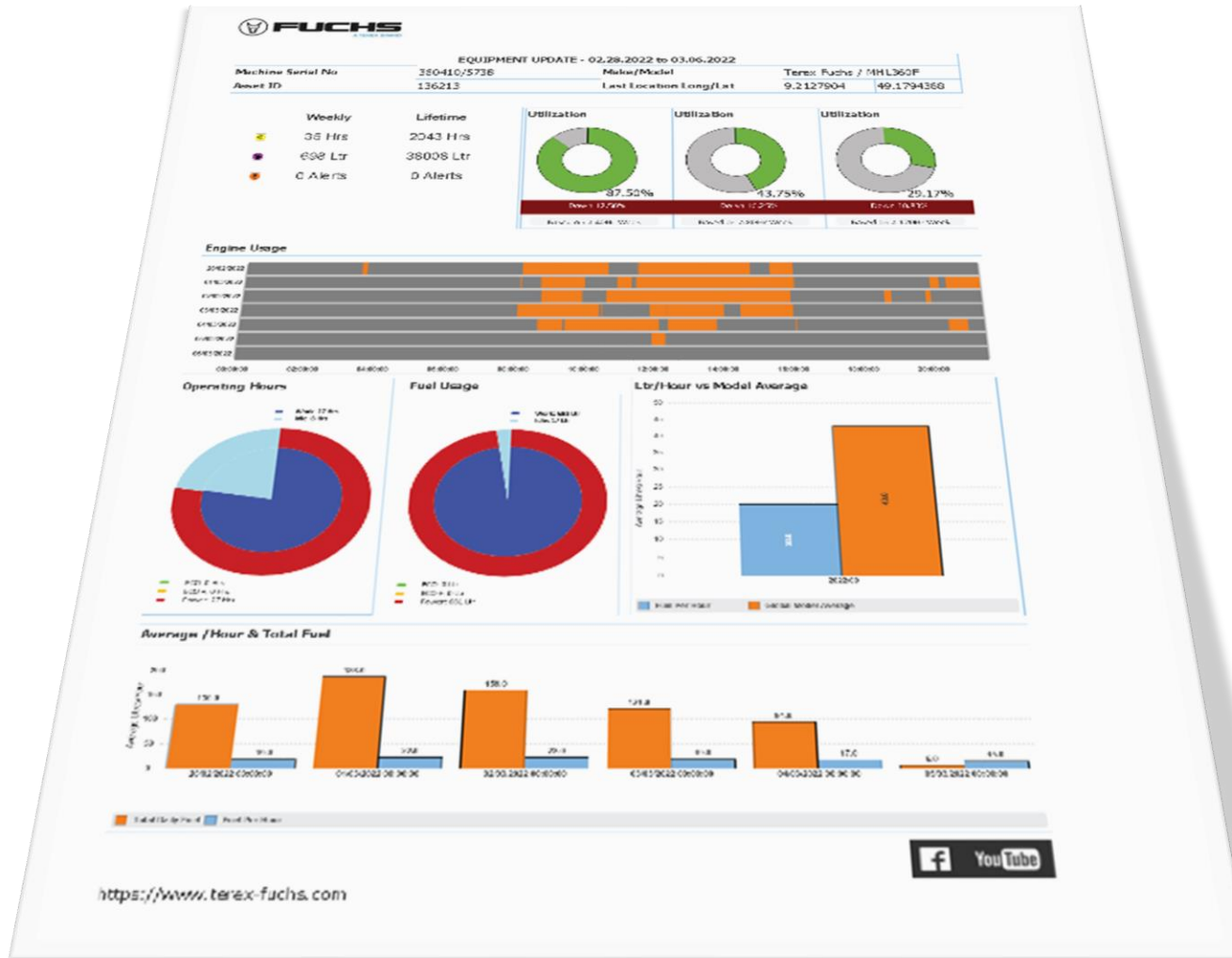

## Advantages:

- ✓ Active weekly reporting
- ✓ Distributed for dealers and customers
- ✓ Usage profile of machines
- ✓ Chance to realize savings

# Fuchs Helpdesk



Create ▾ View ▾ Technical ▾ Admin ▾ My Terex Portal

Technical Helpdesk

Search Issues....



ALL ▾

en-gb ▾

Include Notes



## Advantages:

- ✓ One contact platform with dedicated persons
- ✓ Issues visible for complete team
- ✓ Easy and transparent process



Open Issues

10



Assigned To You

0



Unassigned

1



Owned Issues

0



Closed Issues

1213



# myTerex Customer Fleet App

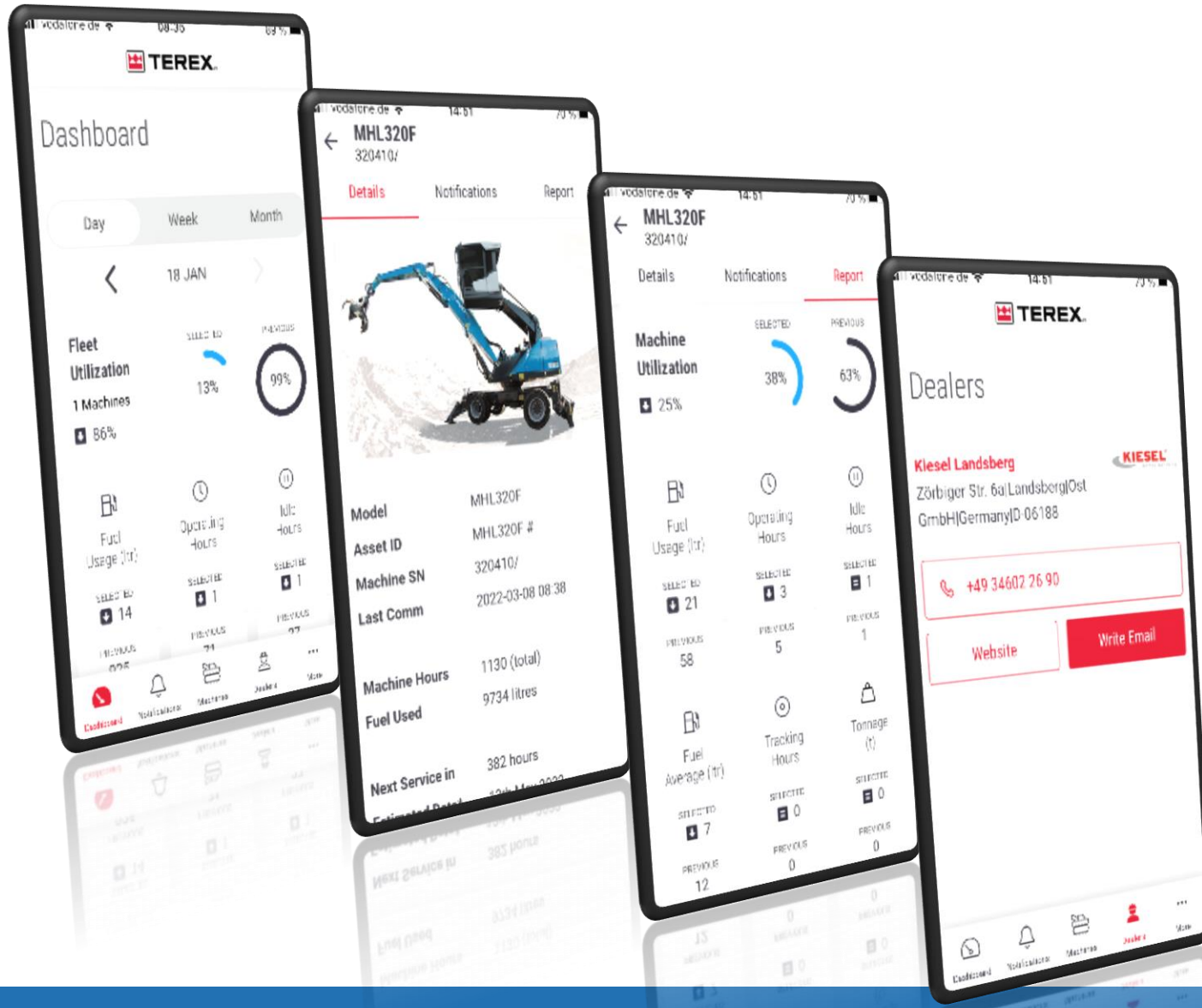

## Advantages:

- ✓ Terex MultiBrand App
- ✓ Designed for customers
- ✓ Included with each machine (active telematics)
- ✓ Available for Android and iOS

# Fuchs OTA Update

## Advantages:

- ✓ Regular Updates with new features and bugfixes
- ✓ Minimized standstill time during update
- ✓ No service tech required at customer site
- ✓ Guided update via the machine display



# Fuchs Look-Up



## Advantages:

- ✓ One system to search for:
  - Spare parts catalogues
  - Unit master cards
  - Operators manuals
  - Service documentation
  - Bulletins
  - Technical knowledge
- ✓ 24/7 available
- ✓ Efficient service with less time for preparation



# Fuchs Remote Assist App



## Advantages:

- ✓ Assistance in tricky situations from the factory without travelling
- ✓ Efficient and quick to maximize machine uptime
- ✓ Available to all Fuchs dealers
- ✓ Available for Android and iOS

# Agenda

- Fuchs a TEREX brand
- Dealer Network in the Region
- Fuchs Value Added Services
- **Testimonials**
- Outlook



**FOUR GENERATIONS OF  
FUCHS MHL**

MHL340 E, MHL350 D & F & MHL360 C

# PORT HANDLING

Testimonial



# PORT HANDLING

Testimonial

**Scrap Handling**  
River Terminal



**Bulk Handling**  
River Terminal

# PORT HANDLING

Testimonial



# PORT HANDLING

Testimonial

**Scrap Handling**  
River Terminal





**Bulk Handling**  
River Terminal



# PORT HANDLING

Testimonial

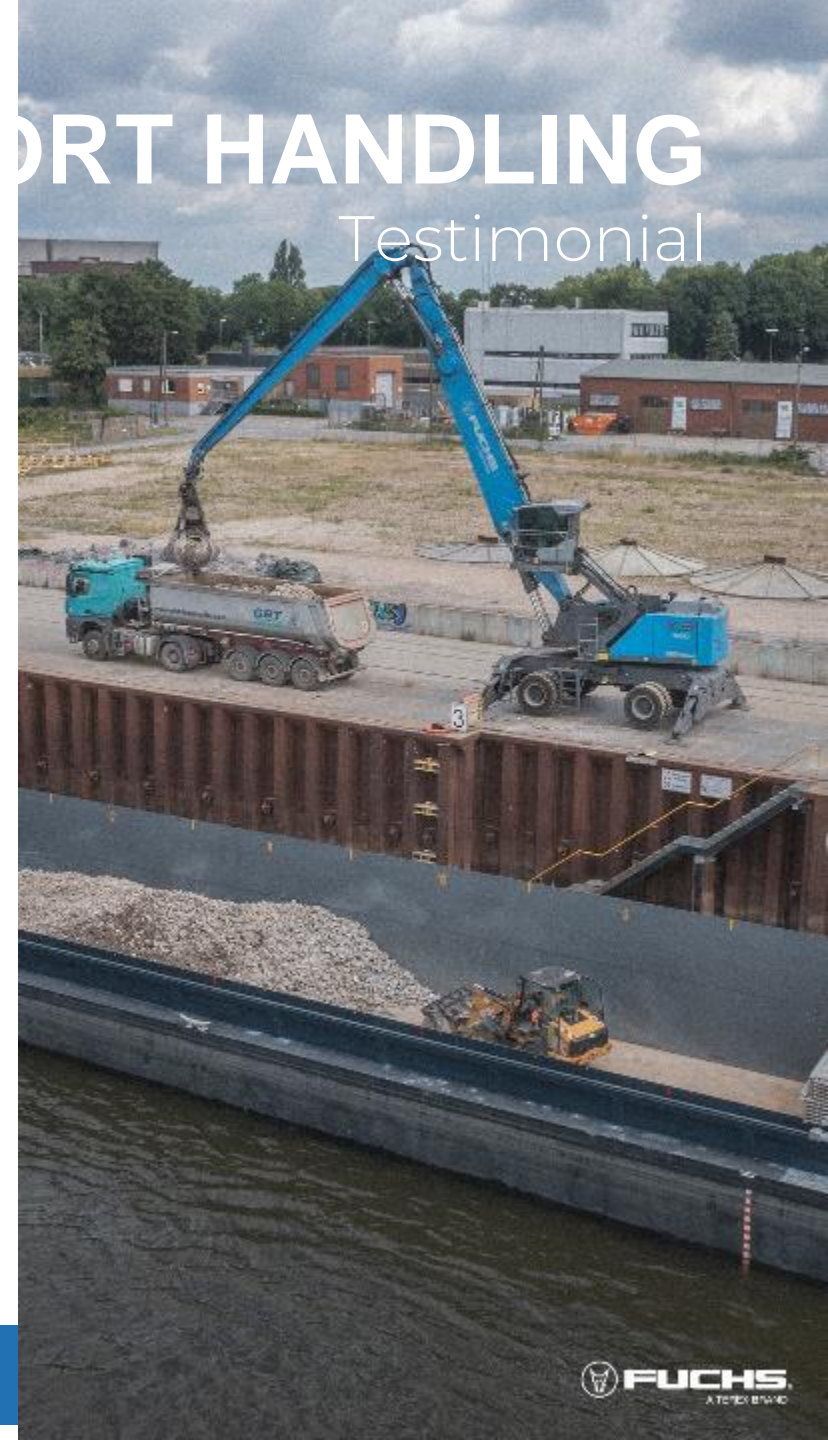



# PORT HANDLING

Testimonial

**Scrap Handling**  
River Terminal



# PORT HANDLING

Testimonial

Dry Bulk Handling  
River Terminal



# PORT HANDLING

Testimonial

**Scrap Handling**  
River Terminal



# PORT HANDLING

Testimonial

**Scrap Handling**  
River Terminal



# PORT HANDLING

Testimonial

Dry Bulk Handling  
River Terminal



**DRY BULK HANDLING**  
River Terminal

# PORT HANDLING

Testimonial



# BREAK BULK HANDLING

Short Sea Shipping

# PORT HANDLING

Testimonial



DRY BULK HANDLING

Seaport

# PORT HANDLING

Testimonial



# Agenda

- Fuchs a TEREX brand
- Dealer Network in the Region
- Fuchs Value Added Services
- Testimonials
- **Outlook**





PORT HANDLING

Testimonial

# UNTIL NOW

## 110 t Gantry

- Max. length: 25 m/ 82'
- Max. weight: 110 t/ 242,000 lbs
- Biggest model in the portfolio



**FUCHS**

A TEREX BRAND

**INTRODUCING:  
The FUCHS Port  
Handling Series**

# F120 MH

## Gantry

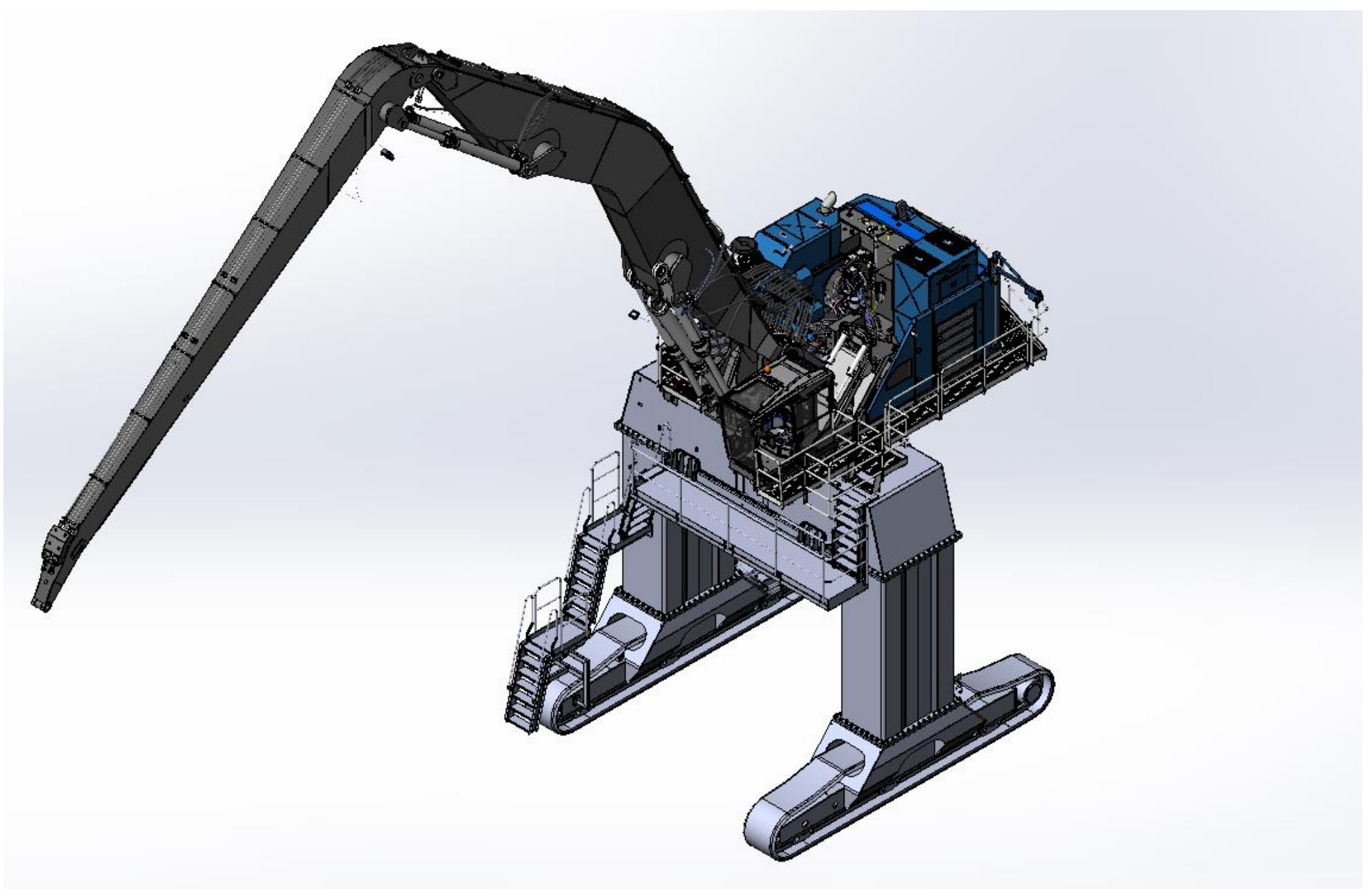

# F120 MH

## Gantry

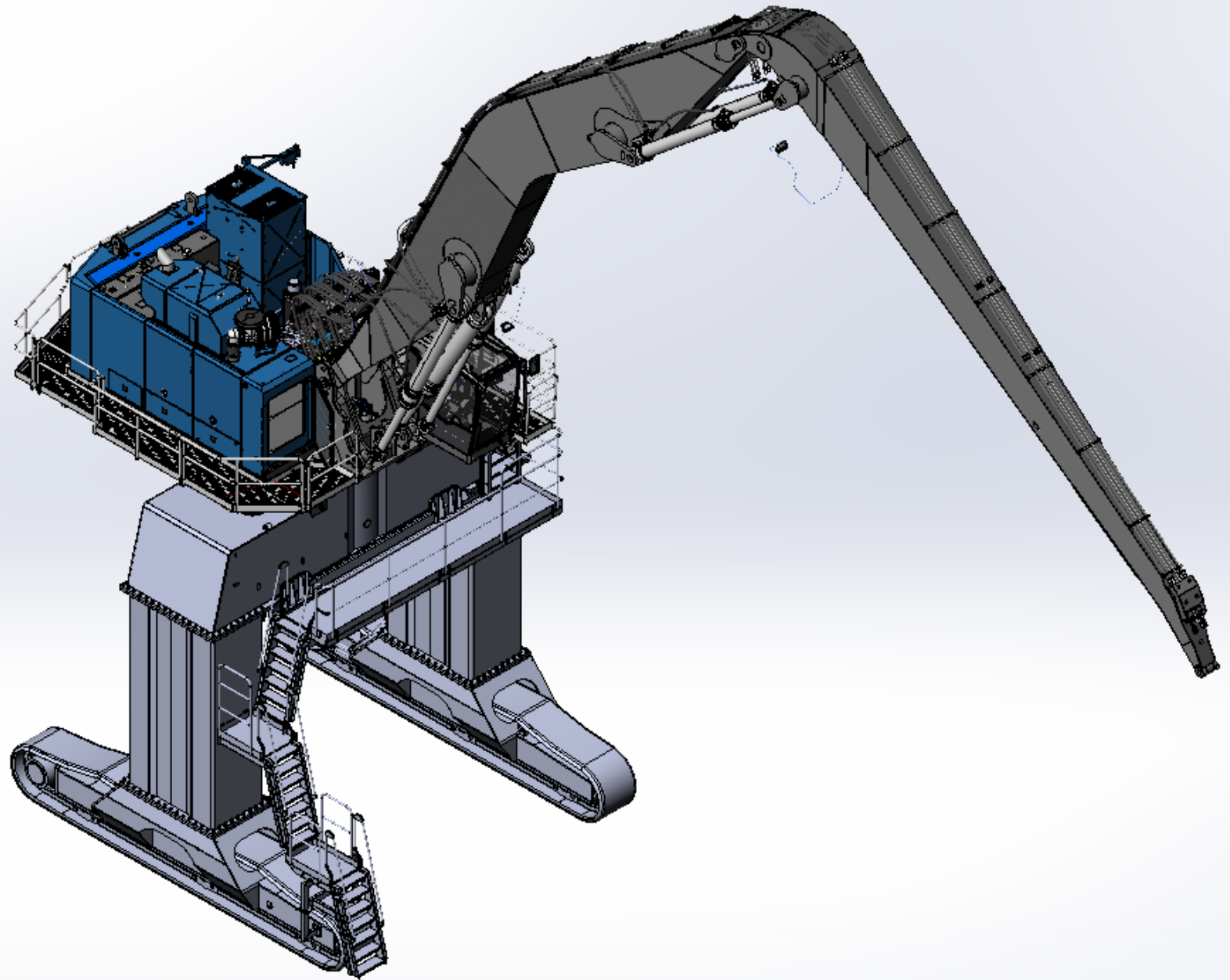

# F120 MH

## Technical Details

- Operating weight starting at **120 t/ 264,000 lbs**
- Min. reach **19 m/ 62'4"**
- Max. reach **27 m/ 88'6"**
- Deutz TCD 12.0 V6
- Hydraulic Hybrid System
- Electric Pilot Control
- **First Model of an ALL NEW portfolio**

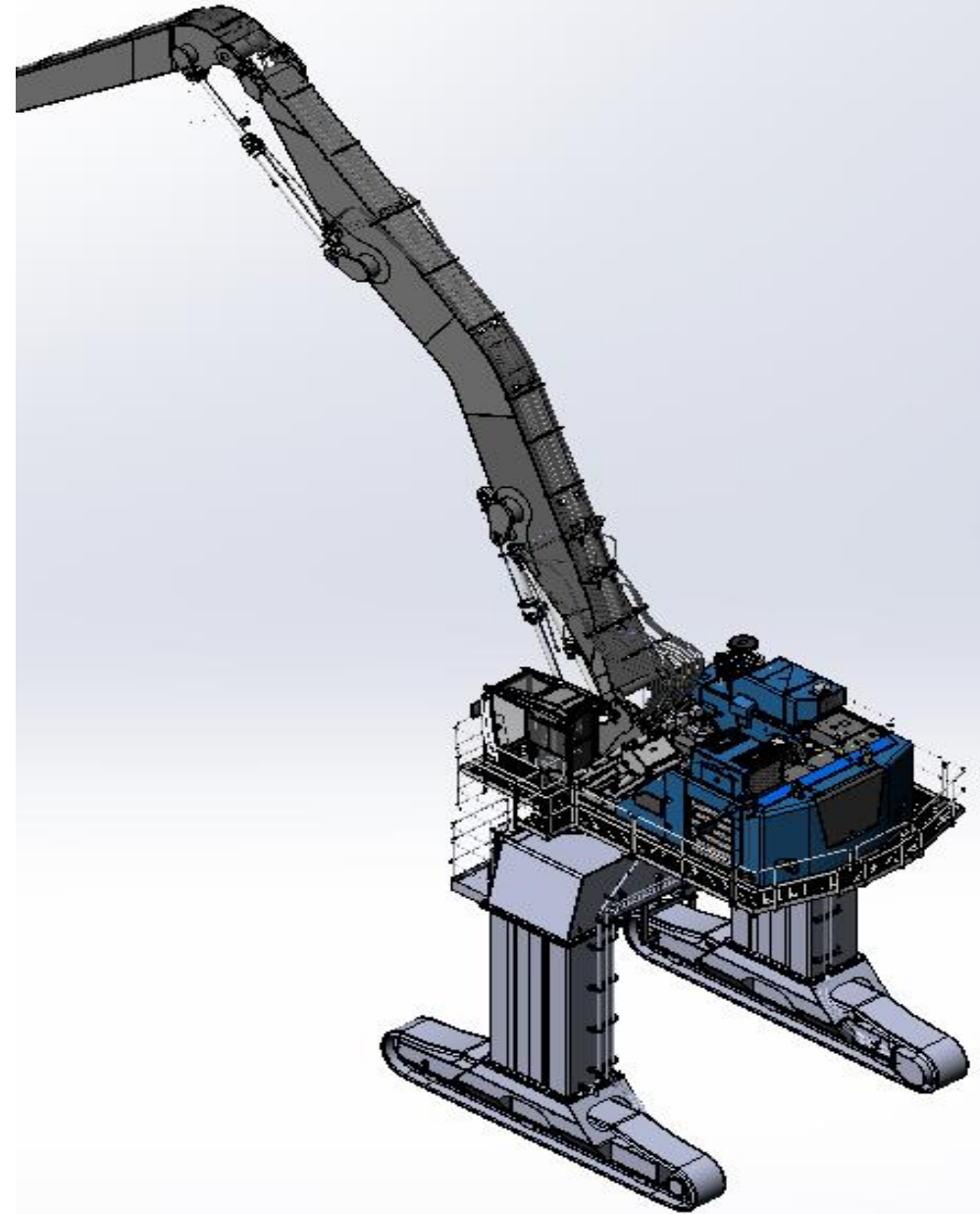

# F120 MH

## Uppercarriage Design

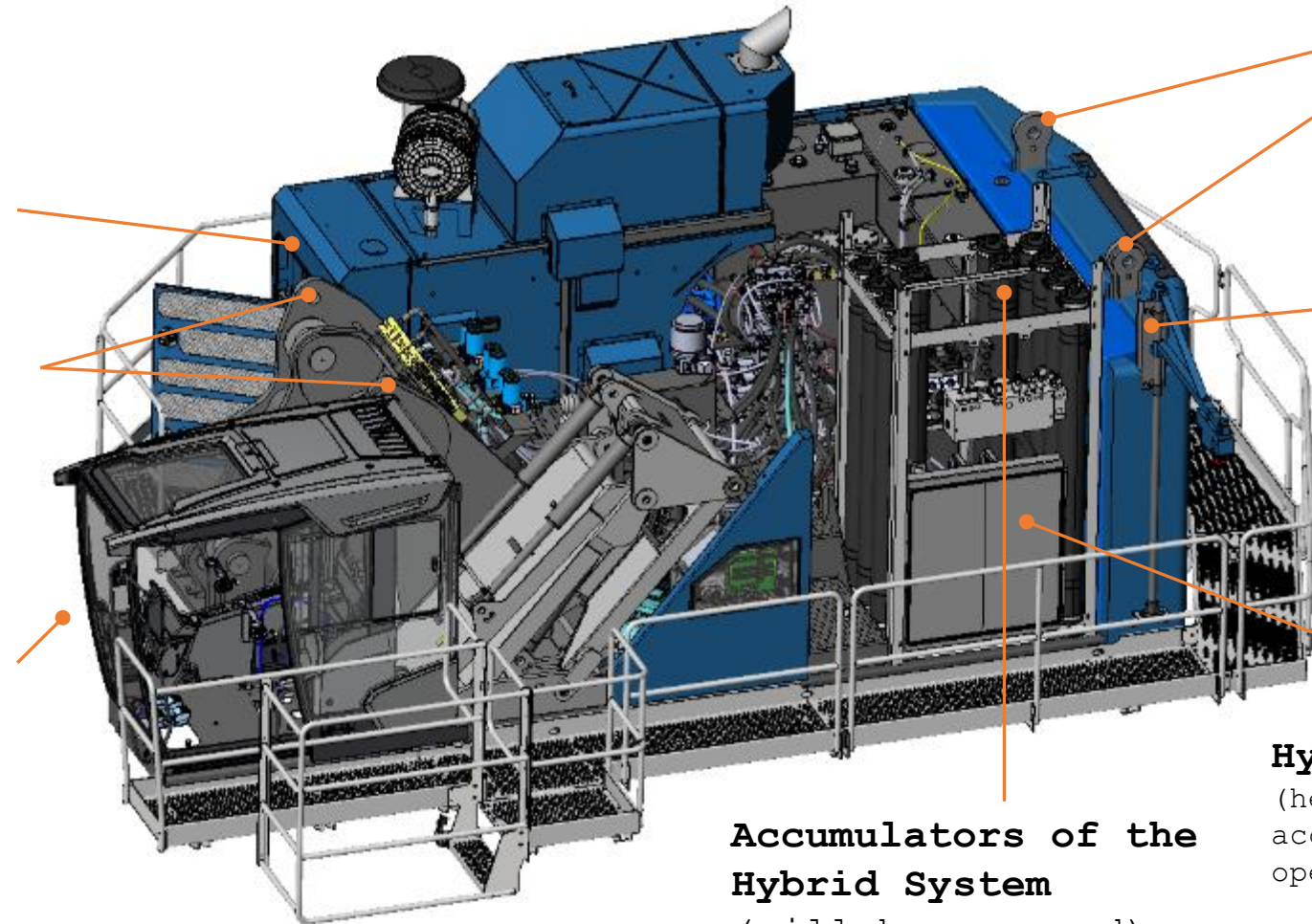

**Hoist Points**

(integrated in the steel frame)

**Water- and Intercooler**

**Service Crane**

(optional)

**Hoist Points**

(integrated in the steel frame)

**FUCHS Comfort Cab  
in & out**

(a bigger „Marina Cab“ will be  
available as an Option)

**Hydraulic-Oil Cooler**

(helps keeping the  
accumulators in the best  
operating temperature)

**Accumulators of the  
Hybrid System**

(will be covered)

# F120 MH

## Uppercarriage Design

**EAT System**

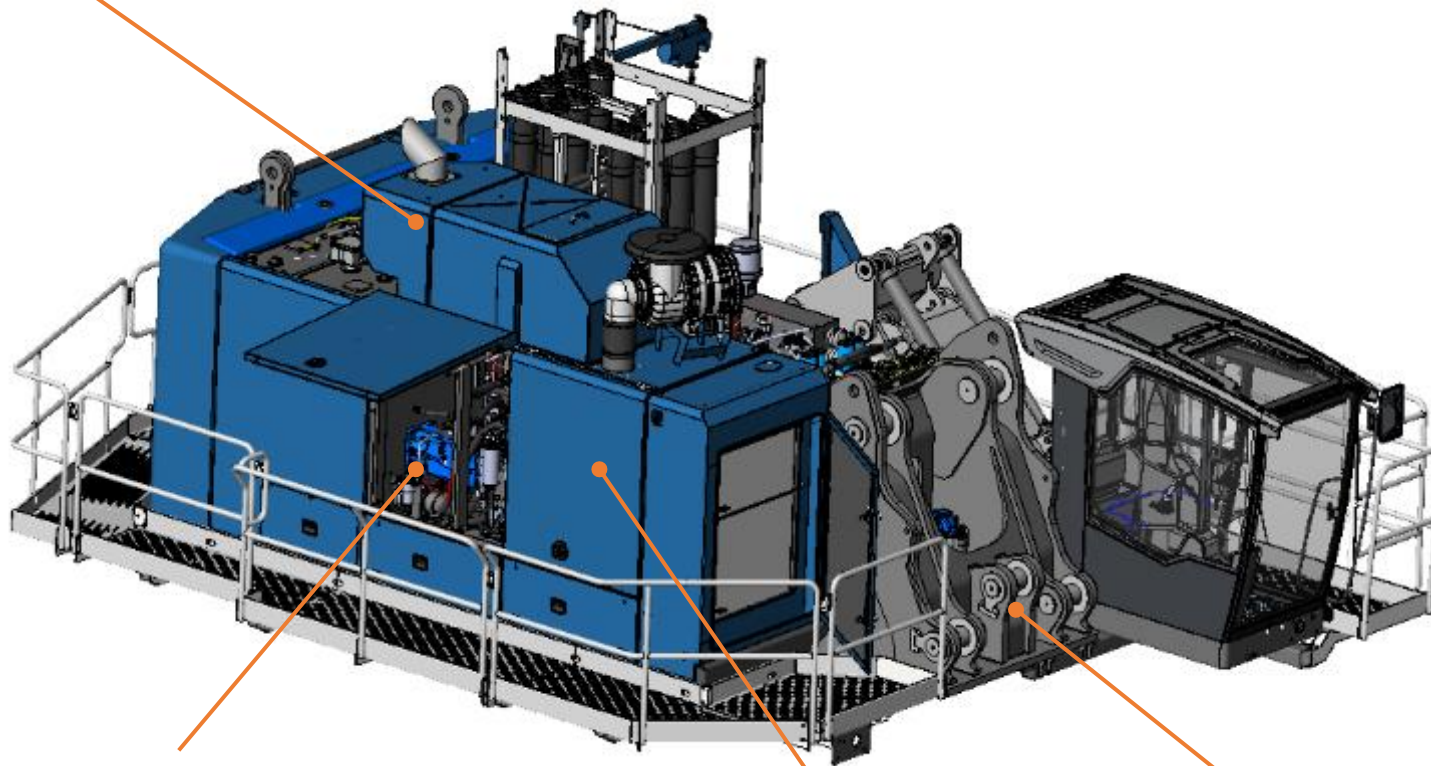

**Engine**  
(Deutz TCD 12.0 V6)

**All covers are made of  
sheet metal**

**3rd. Cylinder**

