

Brake Technology and Monitoring for Increasing Safety and Productivity

Maik Zielberg – technical sales

SIBRE

Sure to be Safe

Siegerland Bremsen

SIBRE Siegerland Bremsen GmbH

- Private owned
- Founded 1958
- Headquarter in Haiger in Germany
- Assembly plant in Eschenburg in Germany
- 17.500 m² production area in Germany
- 260 employees worldwide
- 11 International branches
- 50+ Sales and service partner



AS A ONE STOP SUPPLIER,
SIBRE DELIVERS COMPREHENSIVE
SOLUTIONS FOR ALL DRIVES IN CRANES.



SAFETY-BRAKES

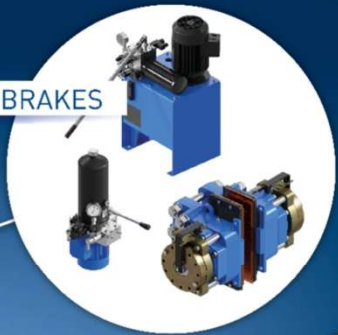

SERVICE-BRAKES



SNAG LOAD PROTECTION



STORM-BRAKES



WHEELS & SHEAVES



COUPLINGS





OUR BRAKES ARE DEVELOPED
BY ENGINEERS AND TECHNICIANS

SIBRE invest to stay future-proof and reliable



HQ Haiger approx. 12 Mio in 2018-2021



Facility Eibelshausen approx. 5 Mio in 2022-2023

USB5 - Designed for all applications in a crane

Identical conditions in regards to installation, adjustment and maintenance

boom hoist
USB5-II or USB5-III

main hoist
USB5-V

trolley travelling
USB5-I or USB5-II

gantry travelling
USB5-05

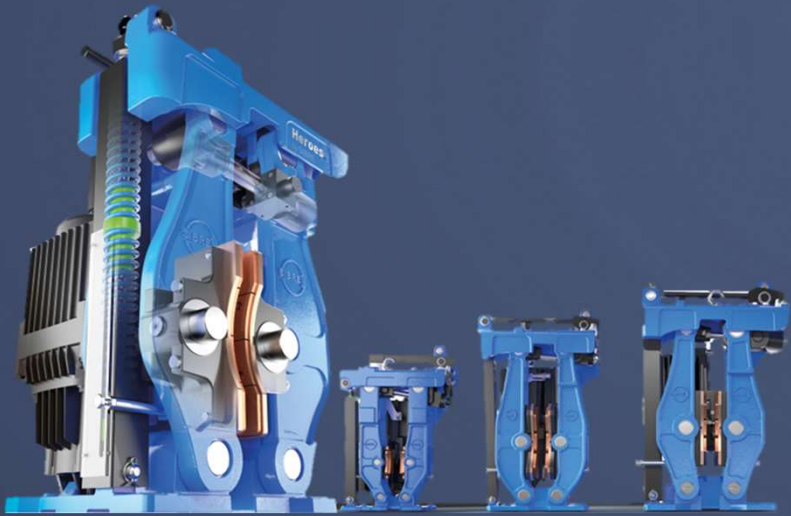

Technical development

All USB5 brakes are equipped with

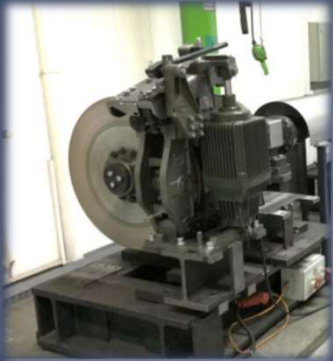

Improved brake linings with stable friction coefficient and brake torque

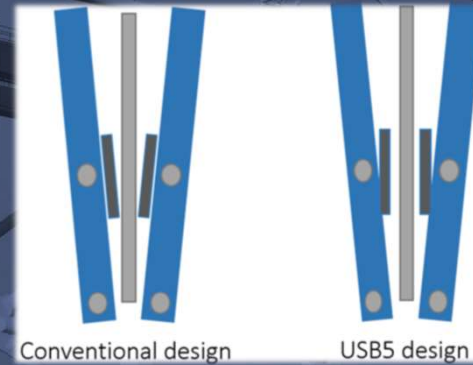

Parallel opening of brake shoes

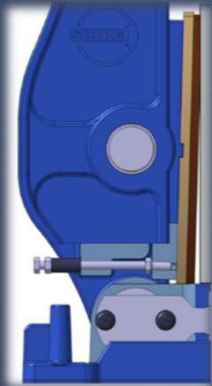

Simplified alignment of the brake system



Upgraded manual release system

Technical development

All USB5 brakes are equipped with



Optimized spring unit with reduced noise emission and extended lifetime of brake spring

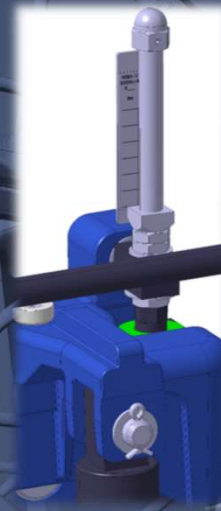

**Optionally with top mounted torque scale
-> easy access from each side**

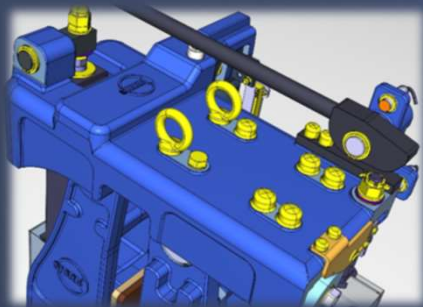

**Enhanced corrosion protection
-> among others, All screws, bolts and washers made of stainless steel -> grade A4-80**



Unpainted parts made of higher grade material and Sinox coated (Instead of tenifer treatment)

SSM

SIBRE

Status

Monitoring



Additional options for status monitoring

All USB5 brakes are prepared for additional sensors

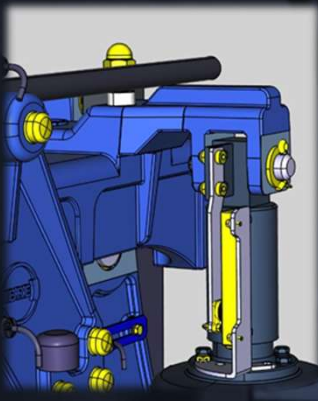

Load cells for brake force and torque measurement

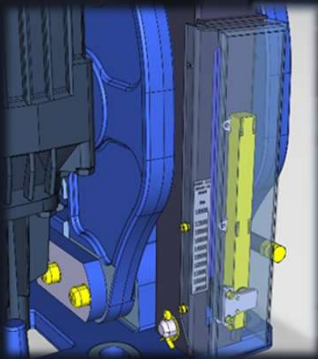

Position sensor (4-20mA) for torque adjustment

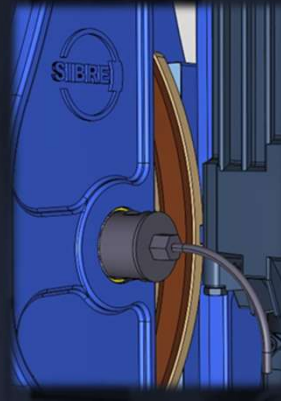

Position sensor (4-20mA) for thruster stroke

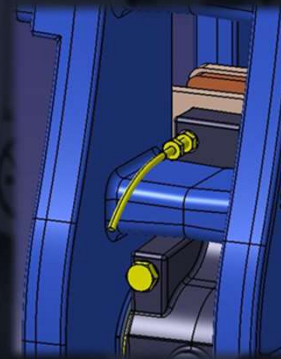

PT 100 temperature sensors for brake linings

A photograph of a trade show booth for SIBRE. The booth features a large circular sign at the top with the SIBRE logo and the slogan "Love to be Safe". Below this, a vertical banner reads "Heroes by SIBRE". To the right, another vertical banner says "SAFETY AND RELIABILITY FOR PORT OPERATION". In the background, a large wall displays the words "SAFETY", "SNAG", "LOAD", "STORM", "CRANE", "STATUS", and "HYDRAU" in large, spaced-out letters. The booth is populated with several people in business attire, some standing and talking, others seated at tables. The overall lighting is dim, with spotlights highlighting the booth's features.

Maximize your operation hours efficacy caused by

- **Increased operational safety**
- **Reduced maintenance requirements**
- **Extended product life span**

Questions? Visit us at booth 28!