



TSUBAKI KABELSCHLEPP

Technology Packages for Cranes and Heavy Duty Applications



Tsubaki Kabelschlepp

Almost 65 years since the initial idea became a patented solution



1953
Invention of the cable carrier
Dr.-Ing. Gilbert Waninger



1954
Foundation of
KABELSCHLEPP GmbH
Dr.-Ing. E.h. Oskar Waldrich



Wenden-Gerlingen Headquarters
all under one roof.

- ▶ Production of all cable carrier system
- ▶ Assembly plant
- ▶ Project division
- ▶ Design and engineering of all products
- ▶ Laboratory
- ▶ Worldwide distribution center
- ▶ Quality management



2010: Integration into the TSUBAKI Group

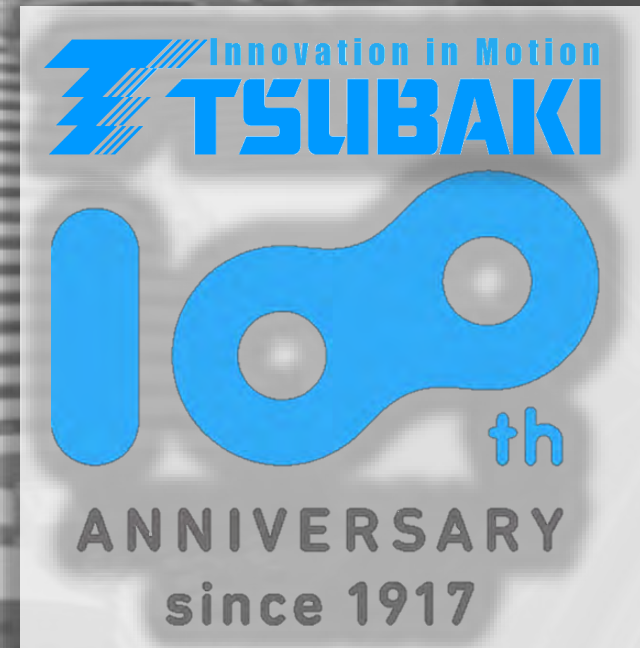

Closely cooperating partners for more than 40 years before becoming part of a successful family

a global Network of specialists available at more than
80 places... even close to you



● Tsubaki Global Network

● Tsubaki Kabelschlepp Global Network

Global set up of crane and long travel specialists

● Crane Expert
Milwaukee

● Head of Crane Division
Sauerland (Germany)

● Crane Expert
Russia

● Crane Expert
Kyotanabe

● Crane Expert
Shanghai

● Crane Expert
Bangalore

● Crane Expert
Singapore

● Crane Expert
Australia

- ▶ Expertise on site
- ▶ Supervising
- ▶ Installation Support
- ▶ Sales specialist
- ▶ Multiplication

Innovative Technologies
Technology packages for cranes

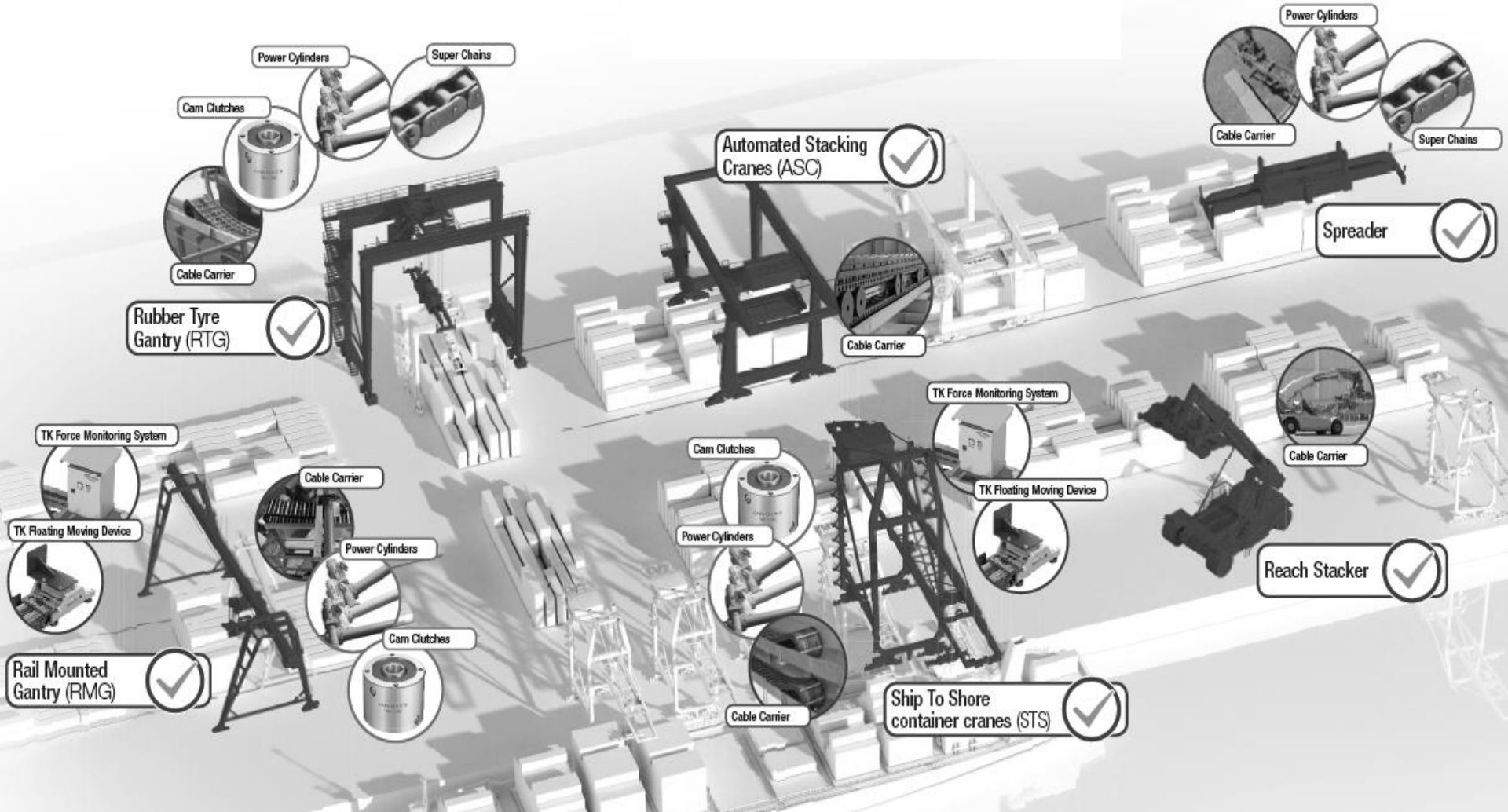

Innovative Technologies Technology packages for cranes

- ▶ TSUBAKI PowerCylinders, Electronical Actuators
- ▶ TSUBAKI Super Chains, Heavy Duty Chains
- ▶ TSUBAKI Cam Clutches, One Way Clutch
- ▶ KABELSCHLEPP Cable Carrier Systems incl. TRAXLINE cables and equipment

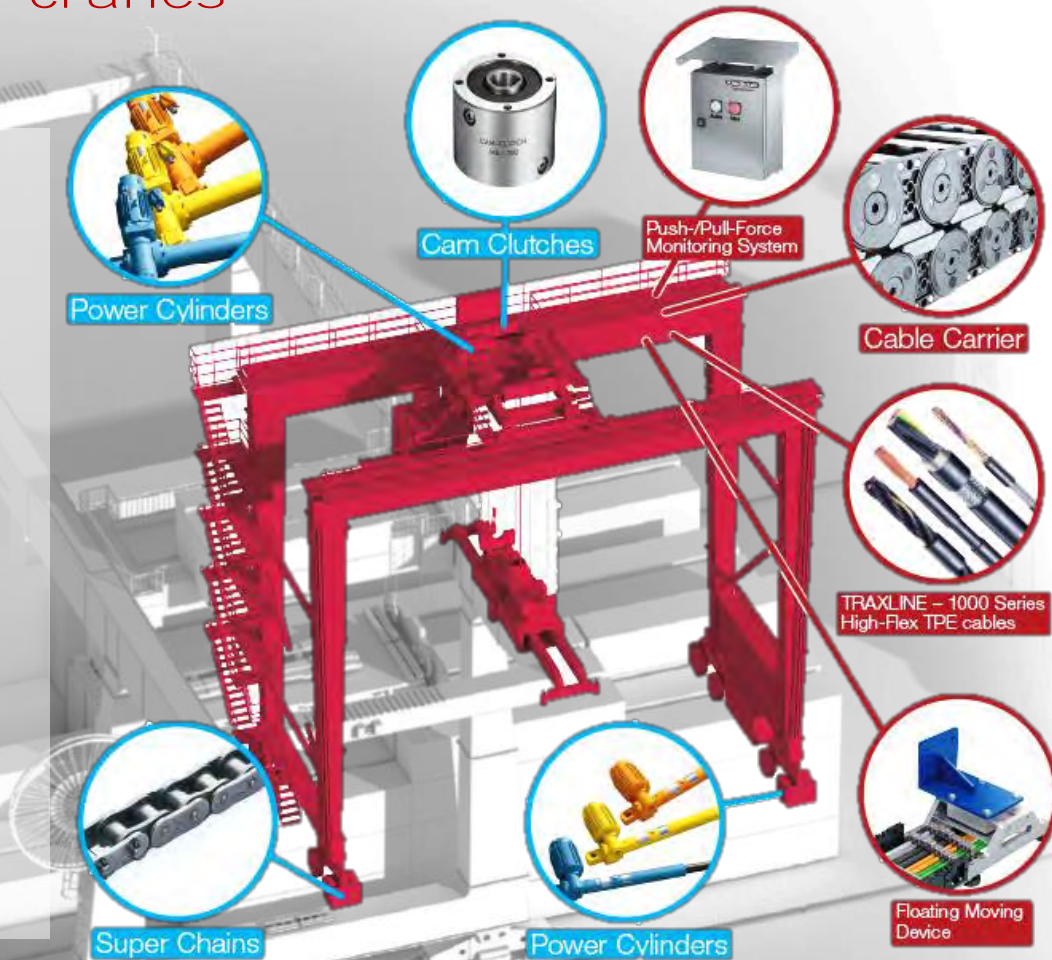

Cable Carriers for crane applications benefits for crane builder and enduser

- ▶ Space saving design
- ▶ No loop station, no additional steel structure
- ▶ No additional drives
- ▶ No control system
- ▶ All kind of media
- ▶ Less mechanical stress
- ▶ Short cable length
- ▶ Easy to maintain
- ▶ Data transfer with light velocity



Tsubaki Kabelschlepp world novelty

TKHD Series

The big black brick

Heavy Duty cable carrier developed for Ship to Shore cranes, Bulk handling and long travel applications
First cable carrier in the market with

- ▶ Inner Height: 87mm
- ▶ Link Pitch: 90mm

TKHD Series for Heavy Duty applications

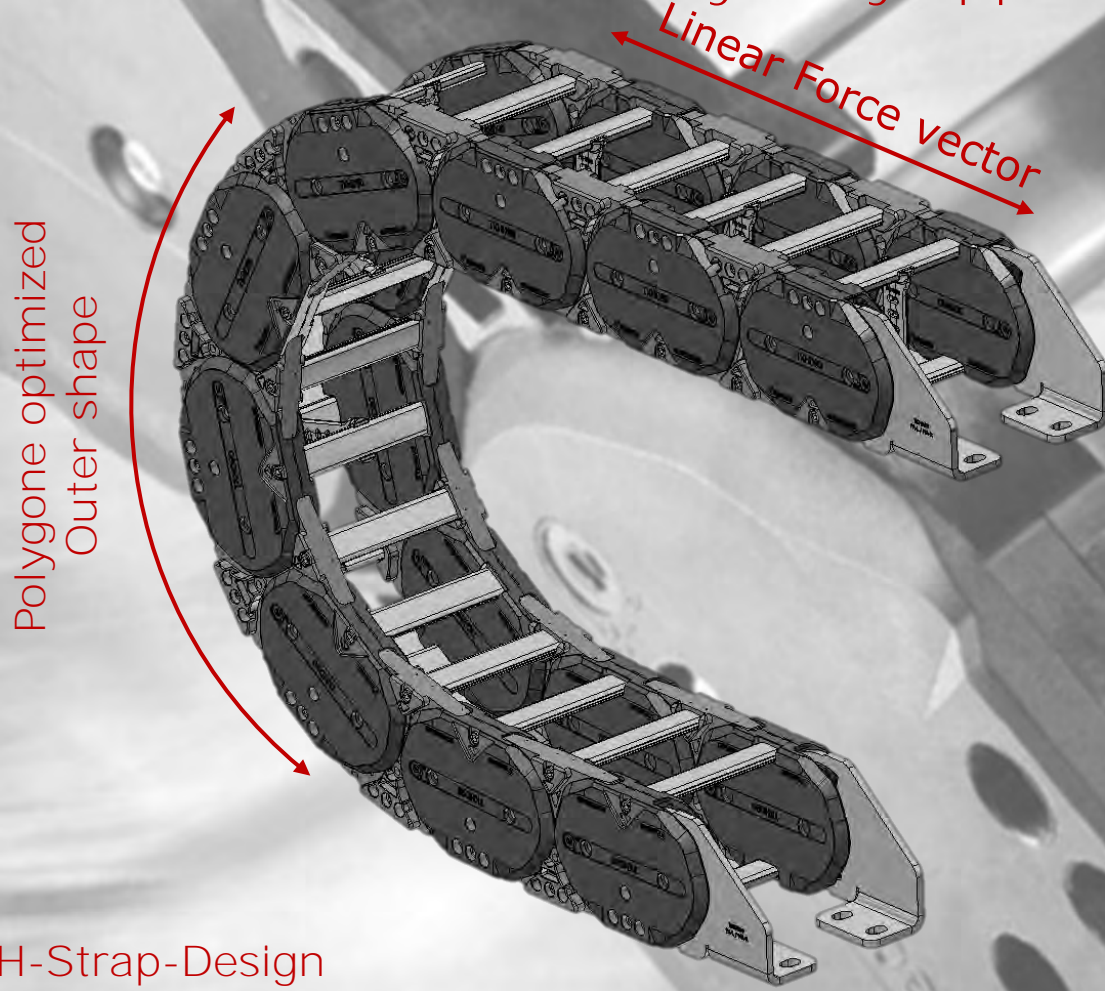

- ▶ Integrated Brake
- ▶ Reinforced stop dog-system
- ▶ 90mm pitch
- ▶ Shape optimized
- ▶ Reinforced bolt hole connection
- ▶ Linear Force curve
- ▶ Massive Design
- ▶ RSC-Version available
- ▶ With glide shoes available
- ▶ Integrated Rollers in planning

TKHD Series for Heavy Duty applications

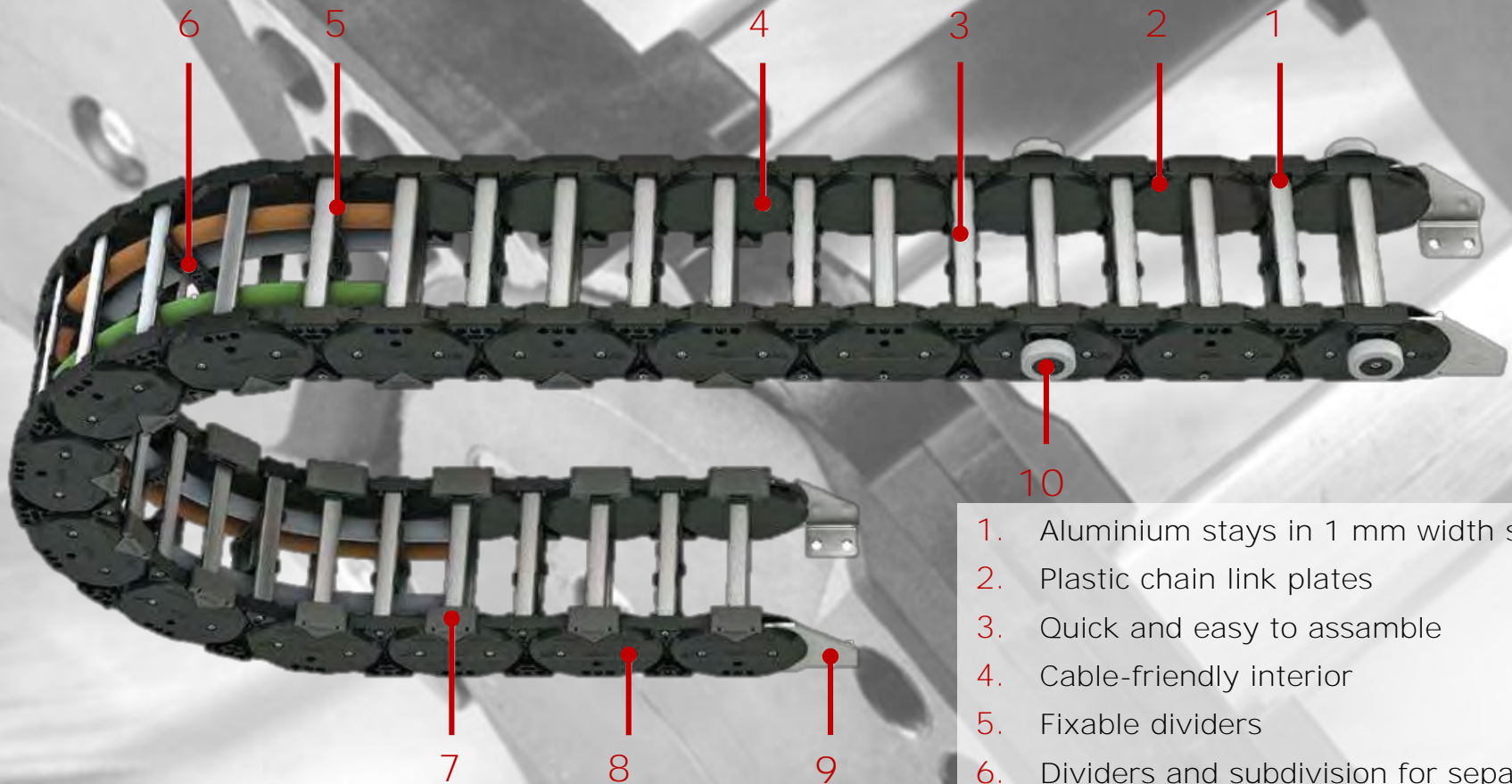

1. Aluminium stays in 1 mm width section
2. Plastic chain link plates
3. Quick and easy to assemble
4. Cable-friendly interior
5. Fixable dividers
6. Dividers and subdivision for separating the cables
7. Replaceable glide shoes
8. Robust, double stop system
9. Steel Installation brackets
10. Alternatively available as RSC-system

RSC-System for Long Travel and Cranes (Roller Supported Chain)



- ▶ Rolling instead of gliding
- ▶ 90% less force compared to a gliding System
- ▶ Quiet and less-vibration
- ▶ High travel speed and acceleration
- ▶ Minimum stress for cable carrier and cables
- ▶ Very long travels possible
- ▶ Easy to maintain
- ▶ Only visual inspection
- ▶ Easy Installation (self aligning)
- ▶ No fix distances of the support Structure necessary
- ▶ For M-Series and TKHD-Series
- ▶ 100% Rolling System



System Guide Channels

- ▶ Standardized
- ▶ galvanized steel and stainless steel,
- ▶ Heavy Duty design with reinforced brackets and sideparts,
- ▶ Preassembled delivery,
- ▶ No welded parts → No heat affected zones,
- ▶ No weldseams → No cracks because of vibrations

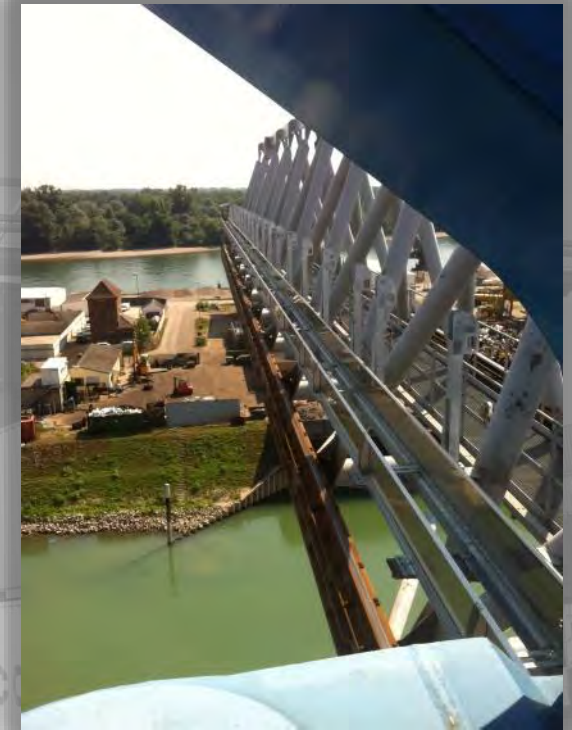

Standardized Housing Systems for TKHD

- ▶ galvanized steel and stainless steel,
- ▶ Heavy Duty design with reinforced brackets,
- ▶ Preassembled delivery,
- ▶ Suitable for System- and RSC-Channel,
- ▶ Suitable for M-Series and TKHD-Series,
- ▶ Easy access to cable carrier,
- ▶ Standardized.

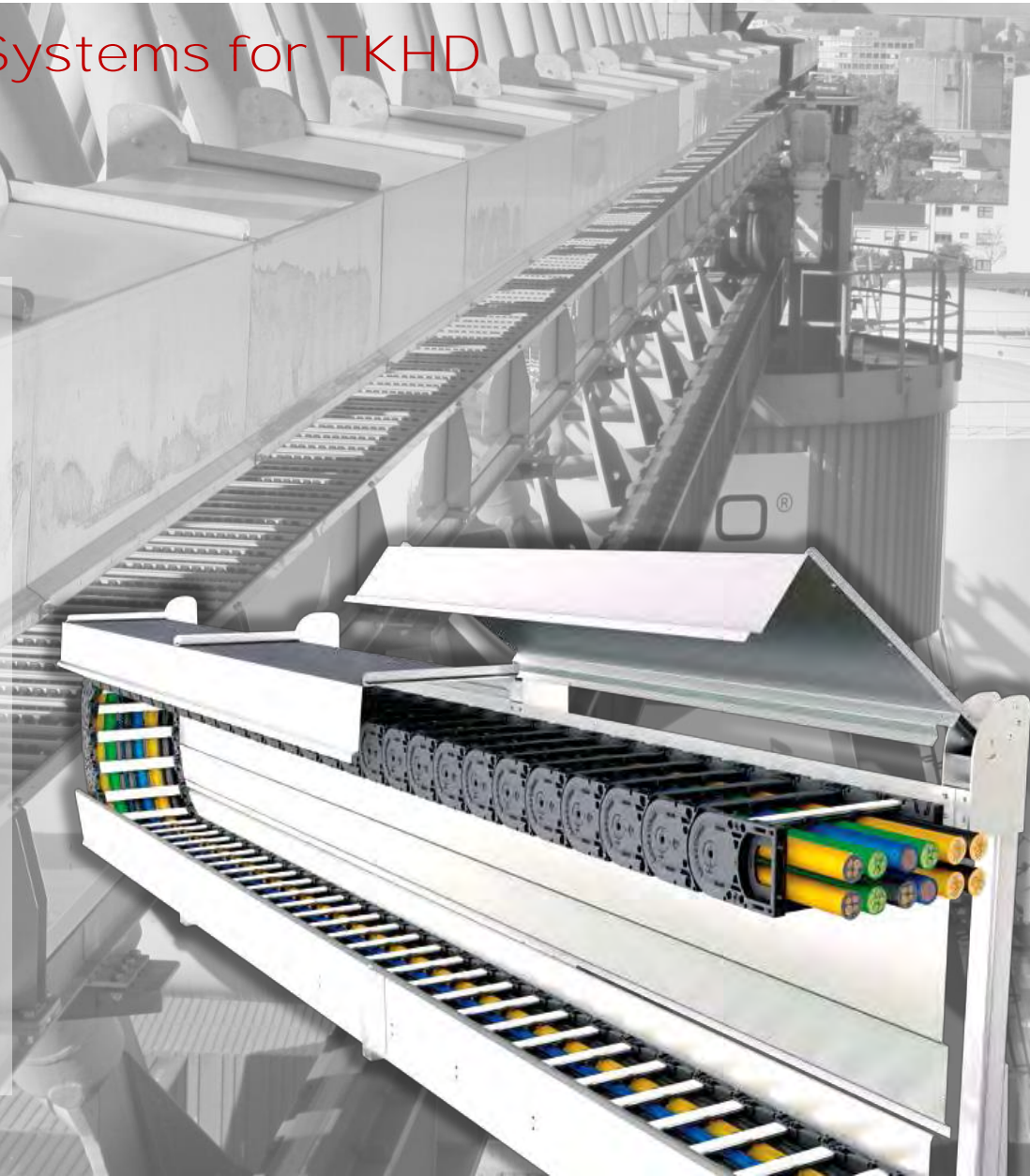

Off-road Glide Shoes for the M-Series

All gliding and rolling applications are affected by wear. To extend the lifetime of a cable carrier, Kabelschlepp developed exchangeable glide shoes.



Biggest advantage:
Instead of changing the whole cable carrier by disassembling it on-site, only the attached glide shoes need to be replaced.
The glide shoes can be removed with a normal screwdriver. Replacing one glide shoe takes only a couple of seconds.

Line-Fix Saddle Clamps

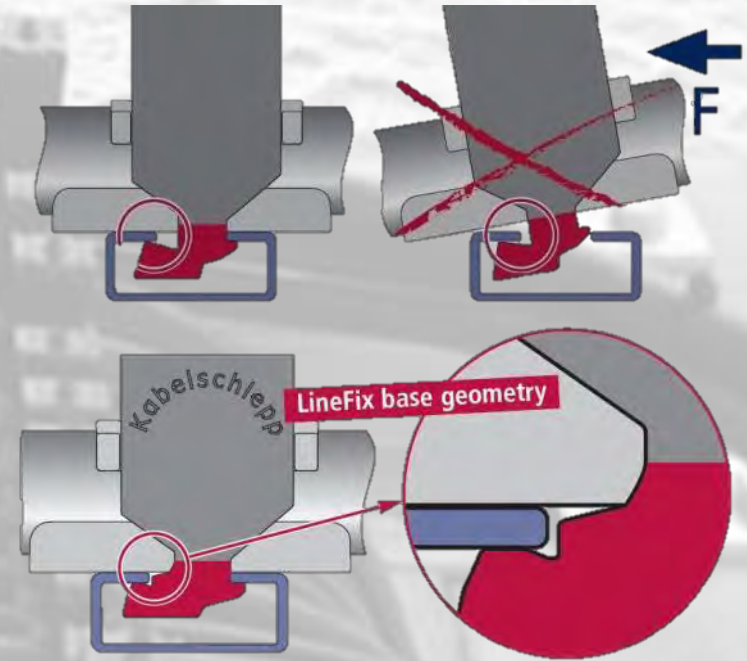

- ▶ steel or stainless steel
- ▶ Optimized base geometry
- ▶ retaining ribs
- ▶ Visible label, even after installation
- ▶ Multi-layer arrangement
- ▶ Fixed with a defined torque

Safety Devices for Cranes Floating Moving Device



- ▶ Compensate horizontal misalignment
- ▶ For all TSUBAKI Kabelschlepp M-Series chains
- ▶ Misalignment compensation:
 - ▶ Vertikal: +/-60mm
- ▶ Also in stainless steel available
- ▶ Easy installation, less maintenance
- ▶ Roller supported
- ▶ Integrated strain relief system
- ▶ Safe cable guidance
- ▶ Combinable with TSUBAKI Kabelschlepp Force Monitoring System

Safety Devices for Cranes

Push-/Pull-Force Monitoring System

- ▶ signal is usable for a fully-automatic emergency stop-system
- ▶ direct measurement of the push-/pull-forces at the moving point
- ▶ force limits freely programmable (lower limit, upper limit)
- ▶ error indication if the limits are exceeded
- ▶ outgoing signal PLC usable (full stop, slow down)
- ▶ internal data storage
- ▶ maintenance free (no battery change)
- ▶ no speed limit
- ▶ for long travel ways
- ▶ protection class IP67



Safety Devices for Cranes „GO-Module“ (Gliding Optimized)

- ▶ gliding optimized
- ▶ Short Loopstation
- ▶ gliding after short distance
- ▶ Force will always in the right direction
- ▶ Less mechanical stress to the system

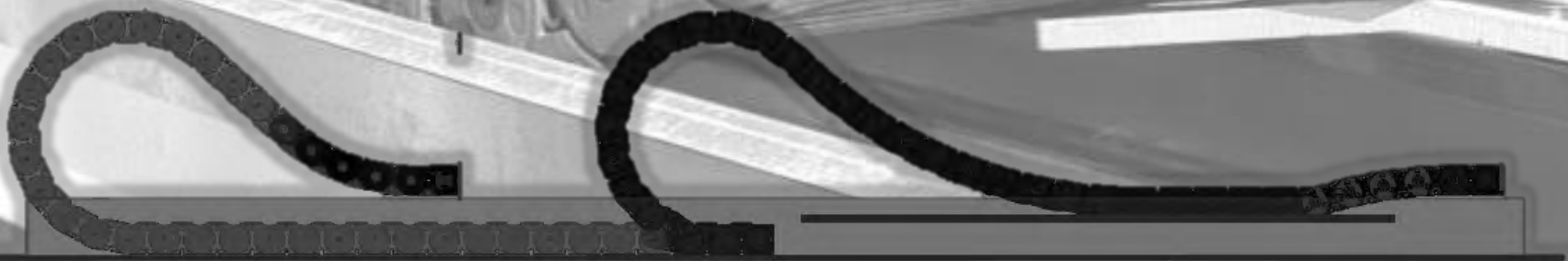

TRAXLINE Cables for Motion

High-flex TPE cables for projects and cranes

- ▶ heavy load and long travel
- ▶ crane and bulk handling equipment
- ▶ systems, mechanical and crane engineering
- ▶ clean room duties
- ▶ limited space solutions
- ▶ permafrost using
- ▶ outdoor applications

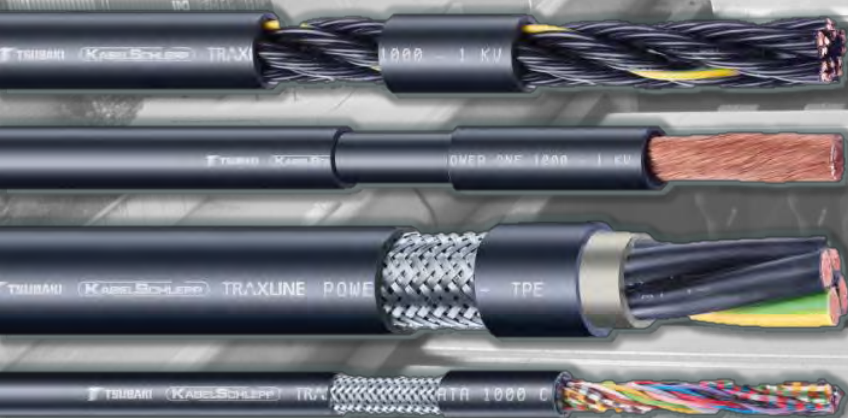

The full TRAXLINE TPE program:

www.traxline1000.de

Total Trax Turnkey System for your crane Application

- ▶ Full harnessed Systems with System warranty.
- ▶ From the first sketch to the final check everything from one supplier.
- ▶ Full System documentation.
- ▶ Full installation service on site.



Preview New Products

Condition monitoring central control unit „intelligent control unit for cranes“

Push-Pull-Force - Monitoring

Wear - Monitoring

Other condition monitoring-tasks

ic4c-System

- ▶ Programmable for different tasks
- ▶ Different tasks available
- ▶ Tablet and smart phone compatible
- ▶ Integrated Ring storage
- ▶ Less program effort
- ▶ Different interfaces
- ▶ Price attractive



Designed and Tested for long lifetime

short and long term tests for
all energychains and cables

- ▶ Free span Tests
- ▶ Long Span Tests
- ▶ Bending Moment Tests
- ▶ Pull Force Tests



Crane Test Facility

Proven under real conditions on outside test facility



- ▶ Test facility for 2 distinct systems
- ▶ Travel lengths of more than 100 m
- ▶ Test speeds up to 5 m/s
- ▶ Test under real weather conditions
- ▶ Automatic Test in 24/7



Crane References

Straddle Carrier

Goliath Crane

Konsolkran

Mobile Harbour Crane

Standard Crane

KBK

Slag Crane

Cantry-Crane

Ladle Crane

Tripper Waggon

Charging Crane

Tippler

Hopper

Craneset

Shipyards Crane

Reachstacker

Indoor Crane

Stacker

Casting Crane

Post Crane

Prozess Crane

Reclaimer

Scrap Metal Crane

Crusher

Ship to Shore Crane

Stacker/Reclaimer

Shipunloader

Rubber Tired Gantry

Mobile Crane

Shiploader

Sidearmcharger

EOT

Jib Crane

Framework Crane

Wall mounted slewing Crane

Coil Crane

Automatic Stacking Crane

Rail Mounted Gantry

Waste Crane

Ship to Shore crane with Roller Supported Chain System



- ▶ Country: China
- ▶ Applicationtyp: STS-Cranes
- ▶ Travelway: 100m
- ▶ Speed: 4,0 m/s
- ▶ acceleration: 0,5 m/s²
- ▶ Additional load: 5 kg/m
- ▶ Cable carrier: RSC MC0950.184.RM.200

Ship to Shore crane
with Roller Supported Chain System



- ▶ Applicationstyp: STS-Cranes
- ▶ Travelway: 115m
- ▶ Speed: 4,0 m/s
- ▶ acceleration: 0,5 m/s²
- ▶ Additional load: 7 kg/m
- ▶ Cable carrier: RSC TKHD90



Shiploader/-unloader

With new Roller Supported Chain System



- ▶ Country: USA
- ▶ Applicationtyp: Grain Unloader
- ▶ Travelway: 147m
- ▶ Speed: 1,0 m/s
- ▶ acceleration: 0,5 m/s²
- ▶ Additional load: 12 kg/m
- ▶ Cable carrier: MC1300.330.RMF-320-79170

Shiploader/-unloader With new Roller Supported Chain System



- ▶ Country: Indonesia
- ▶ Applicationtyp: Ship-Unloader
- ▶ Travelway: 300m
- ▶ Speed: 1,5 m/s
- ▶ acceleration: 0,5 m/s²
- ▶ Additional load: 15 kg/m (incl. Medium Voltage Cables)
- ▶ Cable carrier: MC1300.330.RMF-320-15500

RTGs for Mitsui Engineering & Shipbuilding

- ▶ Company: Mitsui Engineering & Shipbuilding
- ▶ Type of crane: RTG (Turkey, Japan, USA, Malaysia)
- ▶ Travel length: approx. 20 m
- ▶ Speed: 1,7 m/s
- ▶ Acceleration: 0,3 m/s²
- ▶ Additional load: approx. 12 kg/m
- ▶ Cable carrier: MC1300.320-RMF-320-12220



RTGs for ZPMC



- ▶ Company: ZPMC Group, Shanghai
- ▶ Place of usage: within China
- ▶ Type of crane: RTG
- ▶ Travel length: up to 30 m
- ▶ Speed: 1,2 m/s
- ▶ Acceleration: 0,5 m/s²
- ▶ Additional load up to 12 kg/m



RTGs for Trans Gulf Port Cranes



- ▶ Company: Trans Gulf Port Crane, Abu Dhabi
- ▶ Type of crane: RTG
- ▶ Travel length: 17,5 m
- ▶ Speed: 1,2 m/s
- ▶ Acceleration: 4 m/s²
- ▶ Additional load: 12 kg/m
- ▶ Cable carrier: MC0950.352-RS-260



RTGs Kalmar Cargotec



- ▶ Company: Kalmar Cargotec
- ▶ Type of crane: RTG
- ▶ Travel length: 19,1 m
- ▶ Speed: 1,17 m/s
- ▶ Acceleration: 0,5 m/s²
- ▶ Cable carrier: MC1300.320-RMF-320-12220

RTGs for NKM Noell



- ▶ Type of crane: RTG
- ▶ Travel length: 18,40 m, center fixed point
- ▶ Speed: 1,17 m/s
- ▶ Acceleration: 0,3 m/s²
- ▶ Additional load: 10 kg/m
- ▶ KABELSCHLEPP MC 0950.429-RS/RM-260-10.545

Retrofit on all cranes for Contargo



- ▶ Company: CONTARGO, Ludwigshafen
- ▶ Amount: 3 Set
- ▶ Type of crane: STS and RMG
- ▶ Travel length: 108 m/96m
- ▶ Speed: 2 m/s
- ▶ Acceleration: 1 m/s²
- ▶ Additional load 17 kg/m
- ▶ Cable carrier: MC1300.335-RMF-360-57200

RMGs for Liebherr Container Cranes



- ▶ Company: Liebherr Container Cranes
- ▶ Type of crane: RMG Crane
- ▶ Travel length: 94 m
- ▶ Speed: 2 m/s
- ▶ Acceleration: 1,0 m/s²
- ▶ Additional load 12,2 kg/m
- ▶ Cable carrier: MC1250.300-RM-260-50500

RMG, Künz at CTA Hamburg



- ▶ Amount: almost 60 Sets
- ▶ Type of crane: Rail-Mounted Gantry Crane (RMG)
- ▶ Travel length: 32,30 m
- ▶ Speed: 1,0 m/s
- ▶ Acceleration: 0,3 m/s²
- ▶ Opposite Arrangement
- ▶ Additional load 12 kg/m
(divided among two carriers)



Goliath Cranes for STX



- ▶ STX Shipbuilding, Dalian (China)
- ▶ for Upper und Lower Trolley
- ▶ Travel distance: approx. 250 m
- ▶ Additional load: max. 50 kg/m
- ▶ MC1300 with double-sidebands in opposing arrangement

Elevator Application India



- ▶ Cable carrier system for elevator.
- ▶ Close project management between Kabelschlepp India and Germany.
- ▶ Travelway 100m
- ▶ Arrangement: vertical

Compostplant Germany



- ▶ TKHD-RSC Cable carrier system
- ▶ Close project management between Kabelschlepp India and Germany.
- ▶ Travelway 135m
- ▶ Arrangement: opposit running

Experiences

Thousands of outdoor and indoor cranes

- ▶ Straddle Carrier
- ▶ Rubber Tired Gantries
- ▶ Rail mounted Gantries
- ▶ Automatic Stacking Cranes
- ▶ Ship to Shore Cranes
- ▶ Bulkhandling Cranes
- ▶ EOT-Cranes
- ▶ And many many **more...**

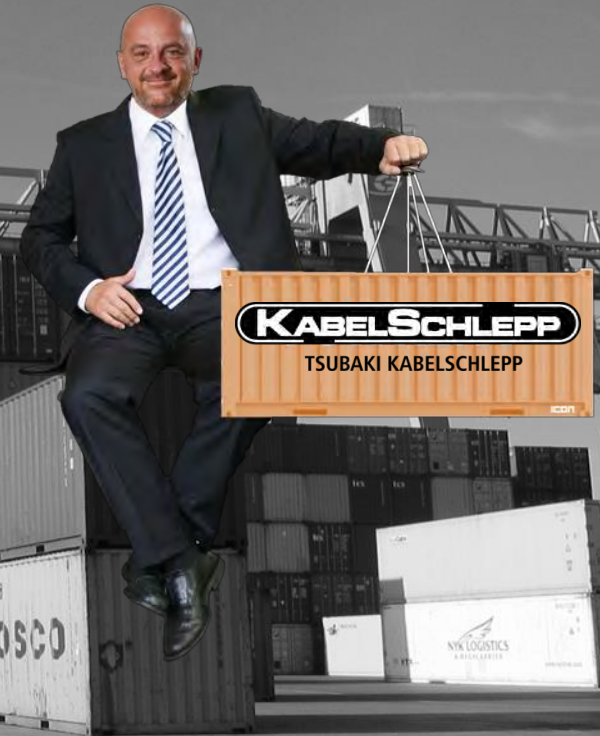

KABELSCHLEPP

TSUBAKI KABELSCHLEPP

Thank you
for your attention!