

# KABELSCHLEPP



## CABLE & HOSE CARRIER SYSTEMS FOR CRANES



# Content:

- 1. Introduction to KABELSCHLEPP and  
TSUBAKI**
- 2. Products**
- 3. References**
- 4. New development: RSC-System**

# Tsubaki KABELSCHLEPP

60 years since the initial **idea** became a **patented solution**



**1953**  
Invention of the **cable carrier**  
Dr.-Ing. Gilbert Waninger  
an employee of von  
H.A. Waldrich in Siegen



**1954**  
Foundation of  
**KABELSCHLEPP GmbH**  
Dr.-Ing. E.h. Oskar Waldrich



## Wenden-Gerlingen Headquarters

Everything under one roof.



- Production of all cable carrier systems made of steel and plastic
- Assembly plant
- Project division
- Design and engineering of all products
- Laboratory
- Worldwide distribution center
- Quality management

## 2010: Integration into the TSUBAKI Group

- For **more than 40 years**, both companies have been closely cooperating partners.
- With this integration, we will leverage our successful business relationship in **one strategic enterprise**.



**TSUBAKI KABELSCHLEPP Headquarters**  
Wenden, Germany



**TSUBAKIMOTO CHAIN Kyotanabe Plant**  
Kyoto, Japan

**a global Network of specialists available at more than 80 places... even close to you**



● Tsubaki Global Network

● Tsubaki Kabelschlepp Global Network (subsidiaries und certified distributors)

**Innovative technologies**  
*for the crane industry*

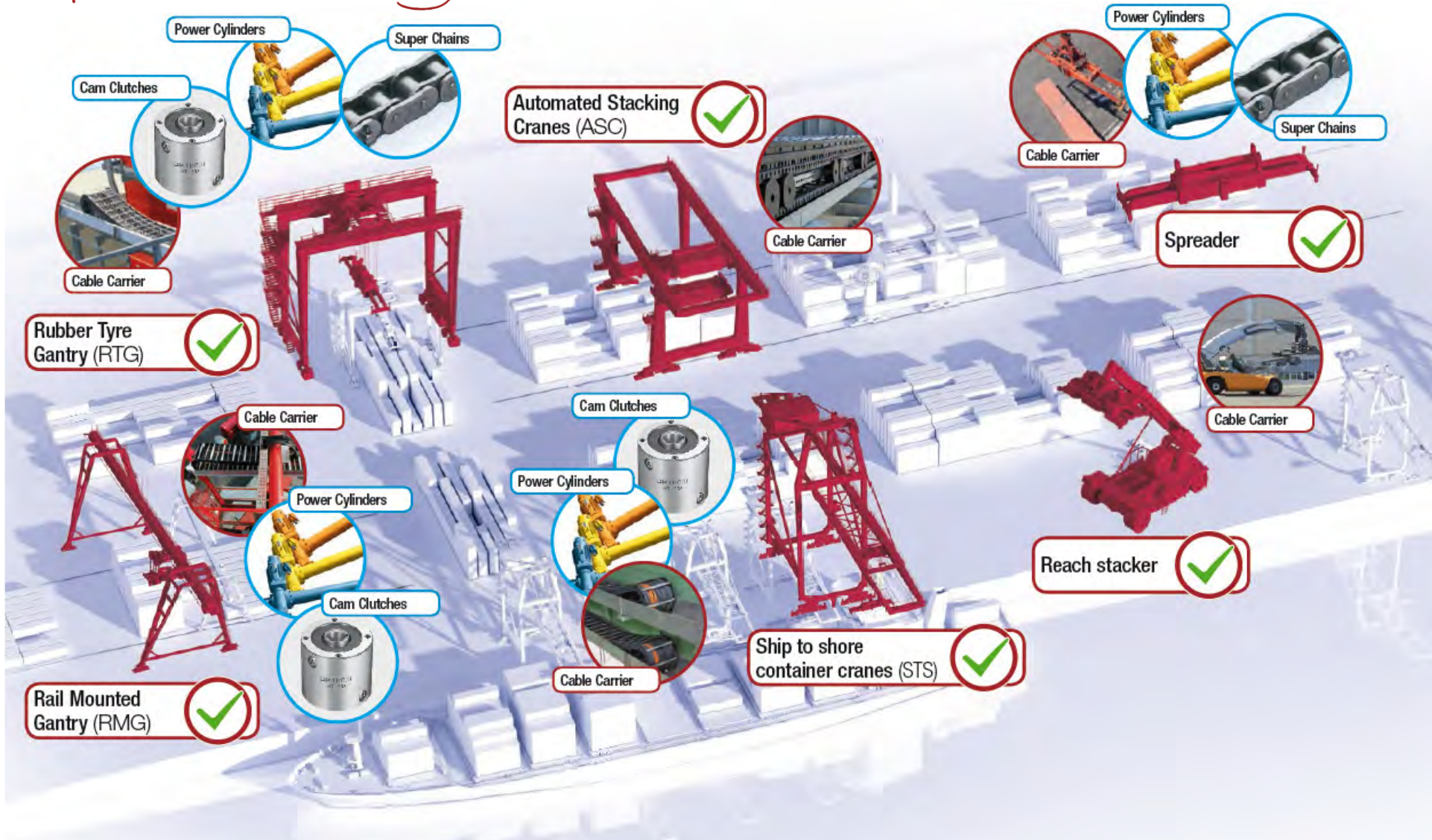

**Innovative technologies**  
*for the crane industry*

- **TSUBAKI** Innovation in Motion PowerCylinders/  
Electronical Actuators
- **TSUBAKI** Innovation in Motion Super Chains/  
Heavy Duty Chains
- **TSUBAKI** Innovation in Motion Cam Clutches/ One  
Way Clutch
- **KABELSCHLEPP** Cable Carrier  
Systems incl. **TRAXLINE** cables

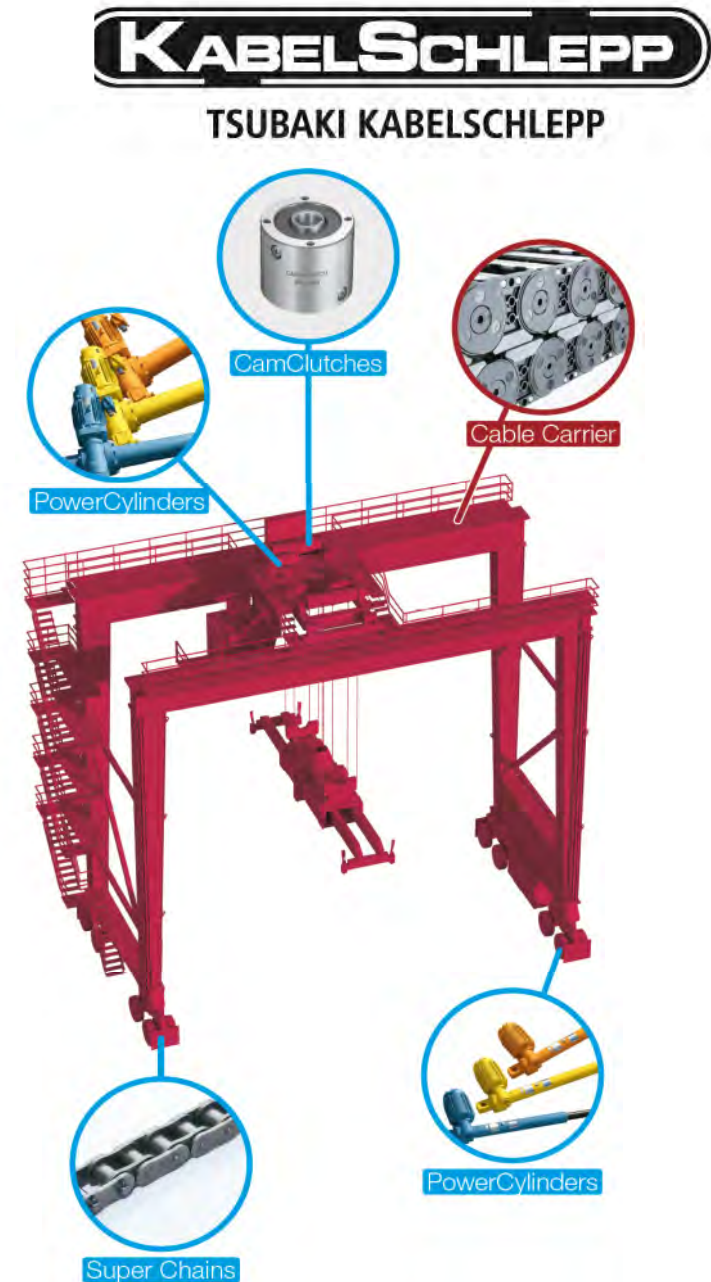



## Cable Carriers for crane applications benefits for crane builder and enduser

- Space saving design
- No loop station and also no additional steel structure for loop station
- No additional drives necessary
- No control system necessary
- All kind of media (power, data, hydraulics, pneumatics, ...) in one System
- No addition mechanical stress to the cables
- Short cable length Easy to maintain
- Safe data transfer via light velocity

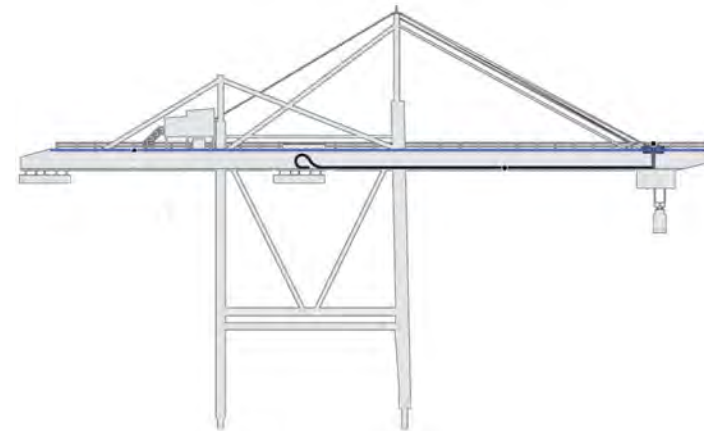

## MC cable carrier with screwed RM/RMF-stays



- Robust design, suitable even for the toughest ambient conditions
- Ideal for extremely long travel lengths
- No fixed inner width
- Bolted crossbars
- Certified Seawaterresistant
- Easy to assemble and maintain



## Off-road Glide Shoes for the M-Series

All gliding and rolling applications are affected by wear. To extend the lifetime of a cable carrier, Kabelschlepp developed **exchangeable glide shoes**.

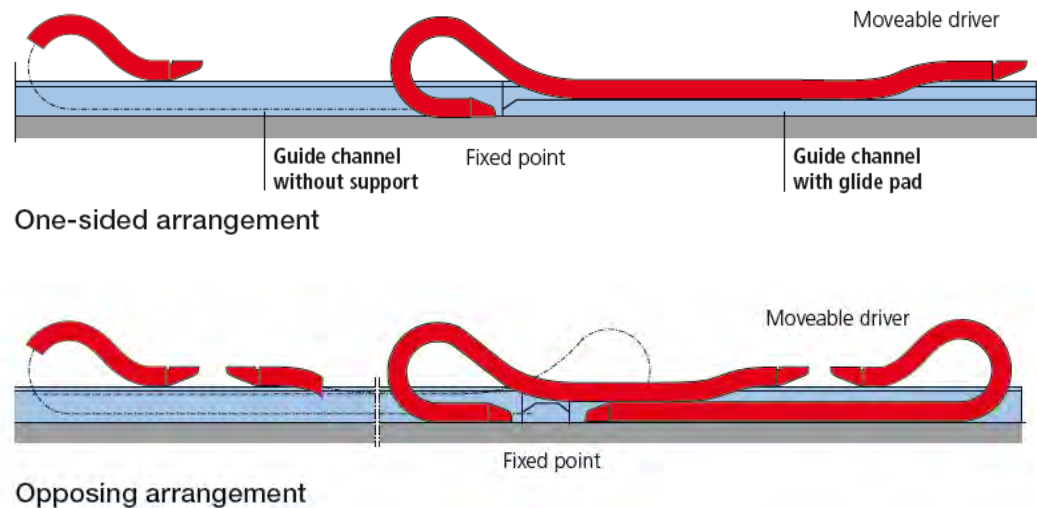

### **Biggest advantage:**

Instead of changing the whole cable carrier by disassembling it on-site, only the attached glide shoes need to be replaced.

The glide shoes can be removed with a normal screwdriver. Replacing one glide shoe takes only a couple of seconds.

## Glide Shoes for the M-Series

Maintenance and inspection friendly design thanks to visible wear marks!

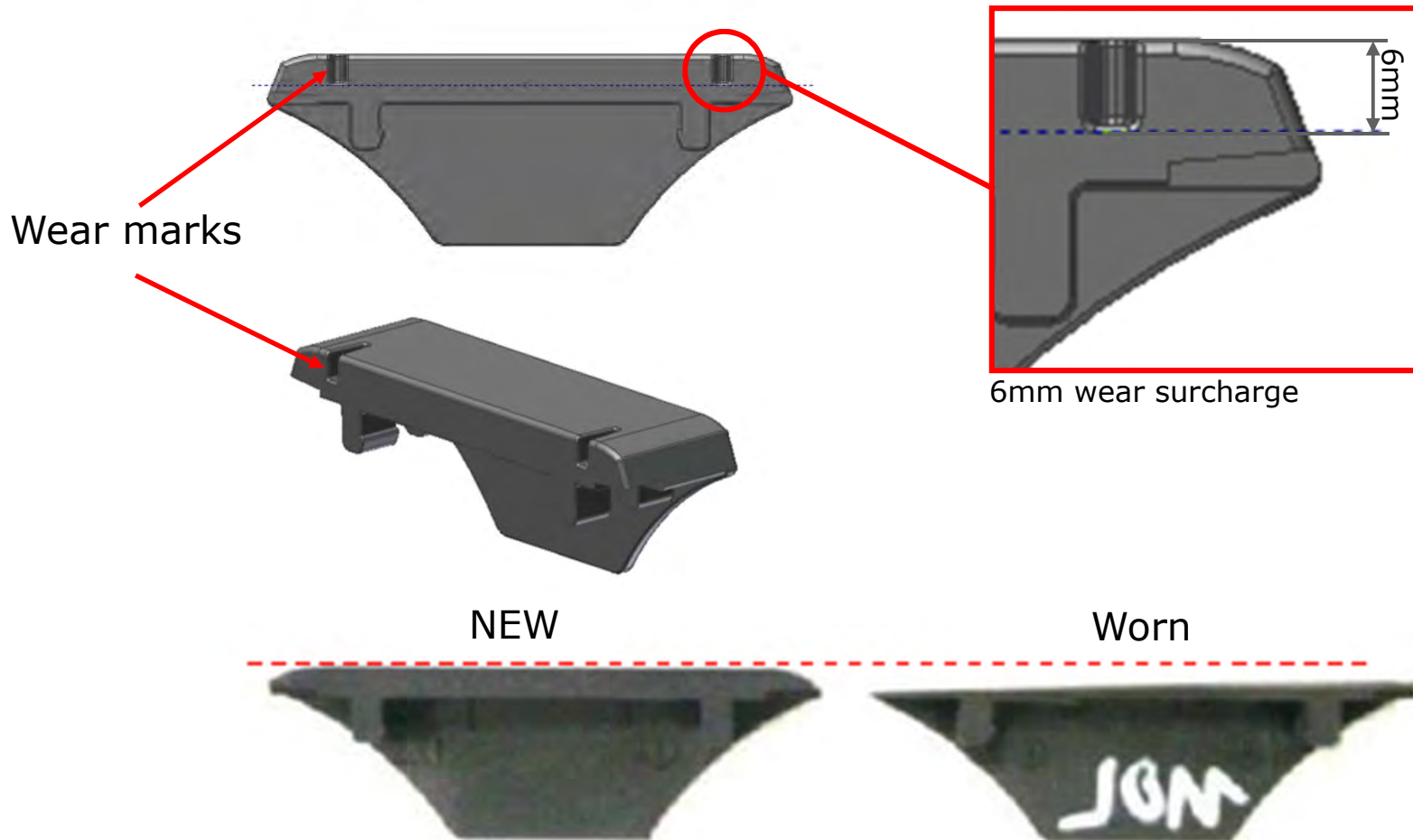

## EXTREME applications

### Steel Cable Carriers

- Robust design for heavy mechanical loads,
- high additional loads and long unsupported lengths possible,
- best suited for extreme and particular environmental influences,
- heat-resistant.

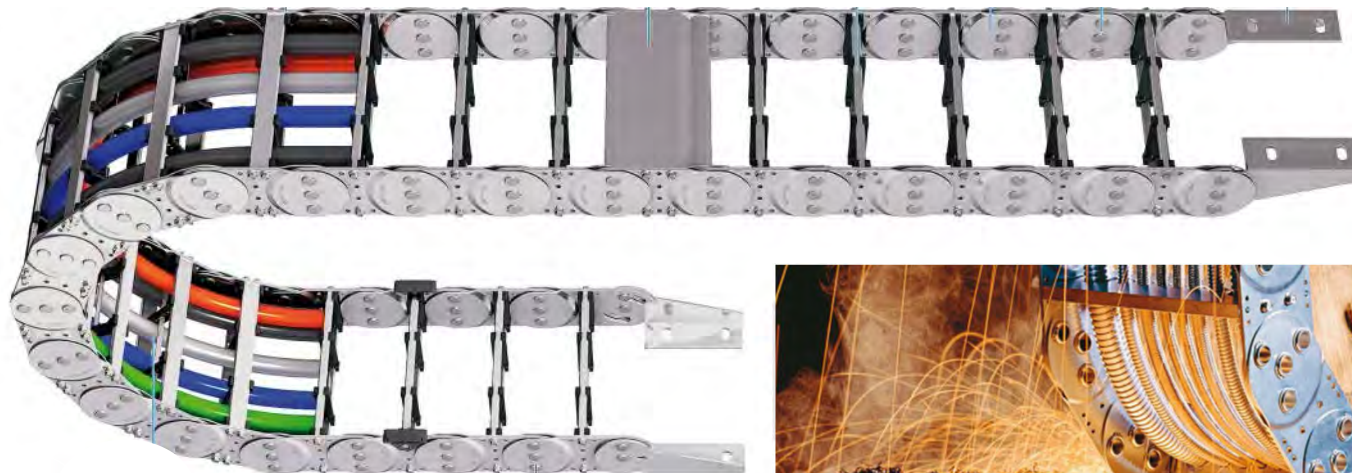

## Guide channel

### Advantages

- **Standardized** for all M Series cable carriers,
- **Available** in galvanized steel and stainless steel,
- **Heavy Duty design** with reinforced brackets and sideparts,
- **Preassembled** delivery,
- **No welded parts** – No heat affected zones,
- **No weldseams** – No cracks because of vibrations

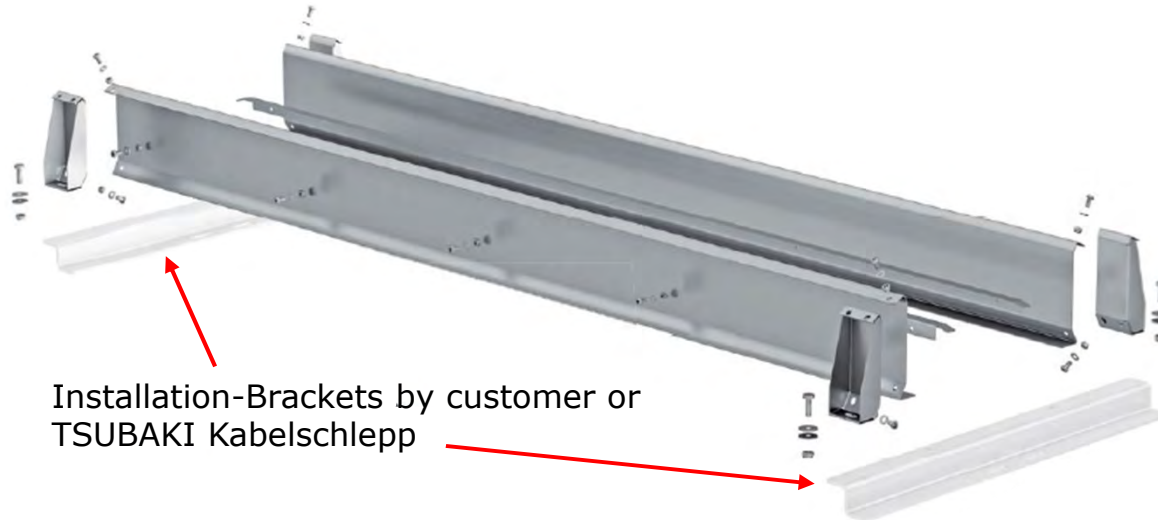

## Driver sledge and rotary insert

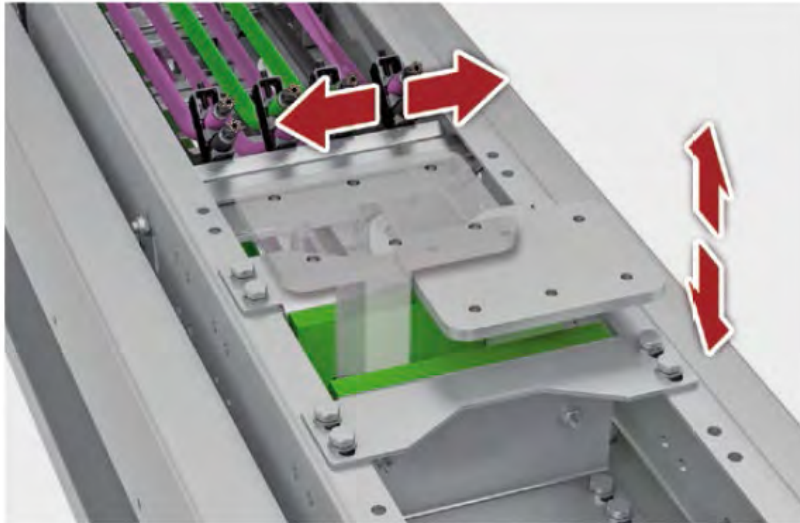

### Purpose of a driver sledge

- Compensate vertical/horizontal misalignment
- Compensate torsional forces

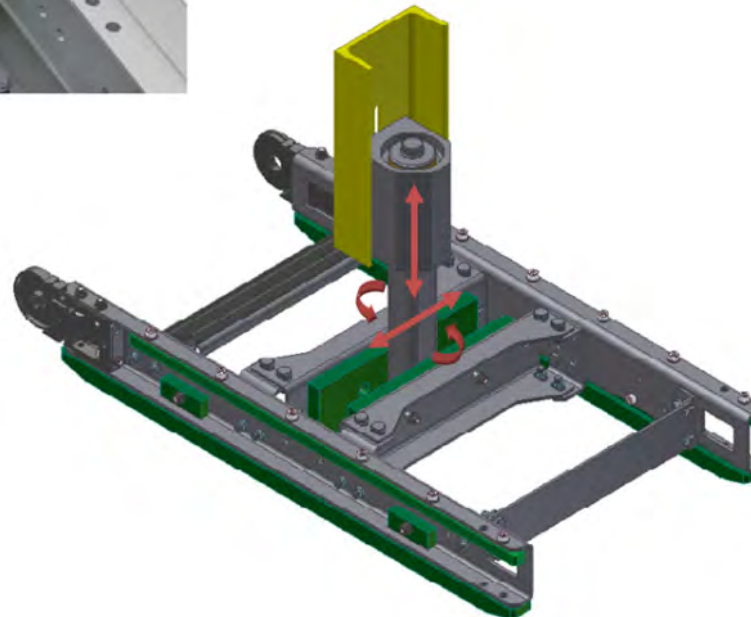

## Line-Fix Saddle Clamps

- Clamps, screws made of steel or stainless steel
- Optimized base geometry
- Plain design with retaining ribs
- Label visible, even after installation
- Multi-layer arrangement possible
- Fixed with a defined torque

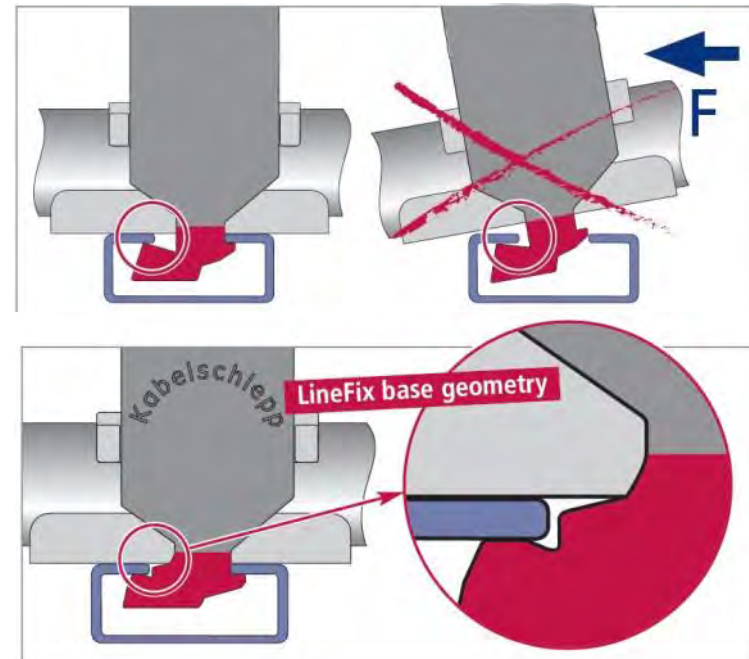



## Safety Devices for Cranes

### Push-/Pull-Force Monitoring System

- signal is usable for a fully-automatic emergency stop-system
- direct measurement of the push-/pull-forces at the moving point
- force limits freely programmable (lower limit, upper limit)
- error indication if the limits are exceeded
- outgoing signal PLC usable (full stop, slow down)
- internal data storage
- maintenance free (no battery change)
- no speed limit
- for long travel ways
- protection class IP67



## TRAXLINE Cables for Motion

### High-flex TPE cables for projects and cranes

#### Developed for

- heavy load and long travel
- crane and conveyor equipment
- systems, mechanical and crane engineering
- clean room duties
- limited space solutions
- permafrost using
- outdoor applications

#### Technical Details

- shielded continuous bending
- top flexdesign TPE power cables
- TPE inner jacket
- special shielding with 85% coverage
- top flexdesign copper wires
- KS-PP core insulation
- outer jacket color: black



**NEW**

The full TRAXLINE TPE program:  
[www.traxline1000.de](http://www.traxline1000.de)

## RSC-System for Long Travel and Cranes (Roller Supported Chain)

- Rolling instead of gliding
- 90% less force compared to a gliding System
- Quiet and less-vibration
- High travel speed and acceleration
- Minimum stress for cable carrier and cables
- Very long travels possible
- Easy to maintain
- Only visual inspection
- Easy Installation (self aligning)
- No fix distances of the support Structur necessary

**100% Rolling System!!!  
the upper Run never  
touches the lower Run**



**Tested at our full automatic crane Test-Center**

## Total Trax Turnkey System for your crane Application

- Full harnessed Systems with System warranty.
- From the first sketch to the final check everything from one supplier.
- Full System documentation.
- Installation service on site.



## MC cable carrier with screwed RM/RMF-stays



Free span tests



Long span tests

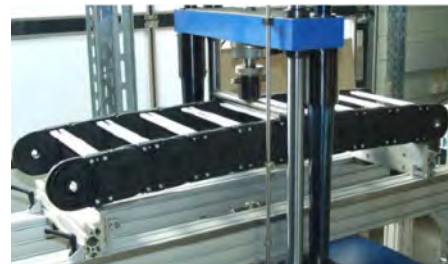

Bending moment tests



Push-pull forces tests

short and long term tests for all energychains and cables



Long travel tests

## RSC-Crane Test Facility

(Roller Supported Chain)

Proven under real conditions on outside test facility

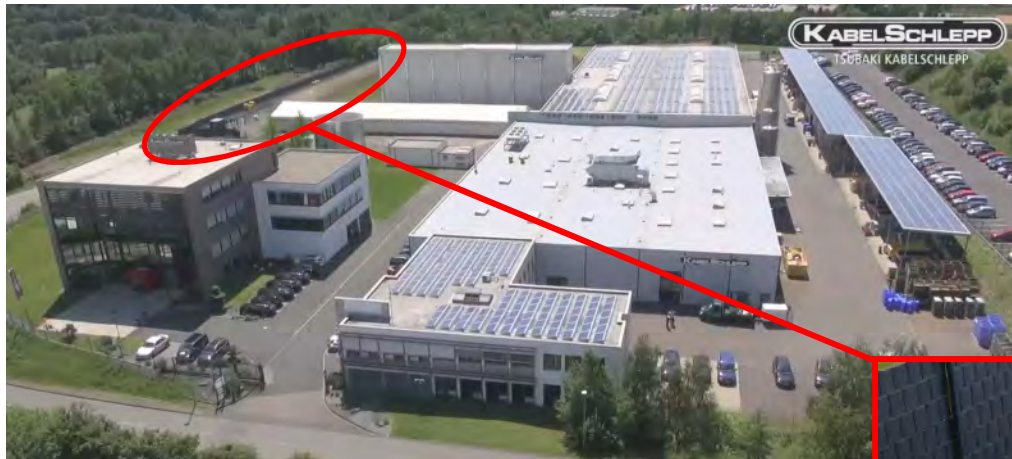

- Test facility for 2 distinct systems
- Travel lengths of more than 100 m
- Test speeds up to 5 m/s
- Test under real weather conditions
- Automatic Test in 24/7





## References



## Shiploader/-unloader

With new **Roller Supported Chain System**

Spezifikation:

Amount:	1 Set
Country:	USA
Applicationtyp:	Grain Unloader
Travelway:	147m
Speed:	1,0 m/s
acceleration:	0,5 m/s <sup>2</sup>
Additional load:	12 kg/m
Cable carrier:	MC1300.330.RMF-320-79170





## Shiploader/-unloader

With new **Roller Supported Chain System**

Spezifikation:

Amount:	1 Set
Country:	Indonesia
Applicationtyp:	Ship-Unloader
Travelway:	300m
Speed:	1,5 m/s
acceleration:	0,5 m/s <sup>2</sup>
Additional load:	15 kg/m (incl. Medium Voltage Cables)
Cable carrier:	MC1300.330.RMF-320-79170

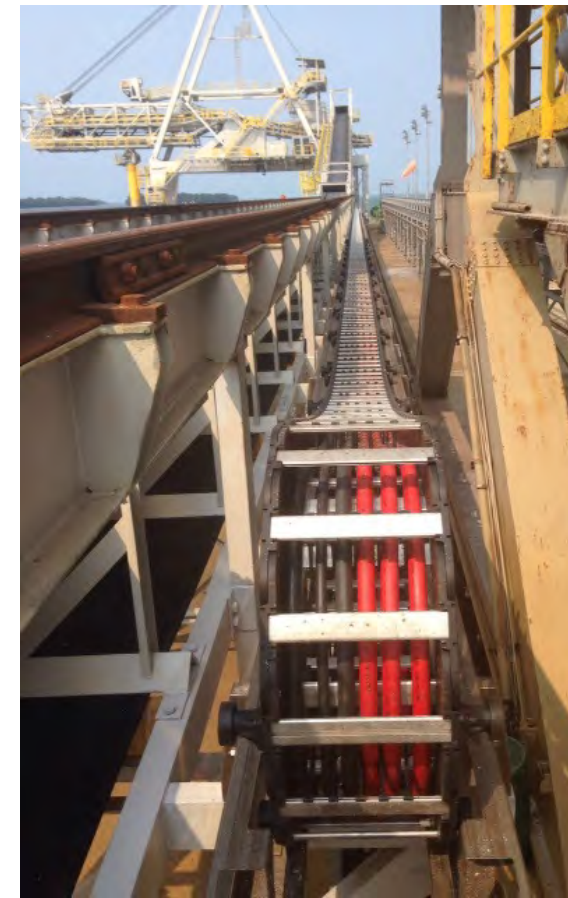

## RTGs for

Specifications:

Company: Mitsui Engineering & Shipbuilding  
Amount: 29 sets (since October 2013)  
Type of crane: RTG  
(Turkey, Japan, USA, Malaysia)

Travel length: approx. 20 m  
Speed: 1,7 m/s  
Acceleration: 0,3 m/s<sup>2</sup>  
Additional load approx. 12 kg/m  
Cable carrier: MC1300.320-RMF-320-12220



TSUBAKI KABELSCHLEPP

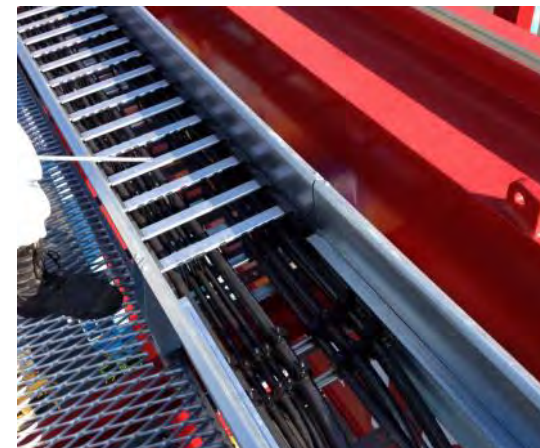



## RTG for



Specifications:

Company: ZPMC Group, Shanghai  
Place of usage: within China  
Amount: several sets  
Type of crane: RTG  
Port environment

Travel length: up to 30 m  
Speed: 1,2 m/s  
Acceleration: 0,5 m/s<sup>2</sup>  
Additional load up to 12 kg/m



**RTGs for**



*Trans Gulf Port Cranes L.L.C*

عبر الخليج لرافعات المرافئ ذ.م.م

Specifications:

Company: Trans Gulf Port Crane, Abu Dhabi  
Amount: 13 Sets  
Type of crane: Rubber Tyred Gantry (RTG)  
Port environment

Travel length: 17,5 m  
Speed: 1,2 m/s  
Acceleration: 4 m/s<sup>2</sup>  
Additional load 12 kg/m  
Installation:  
Cable carrier: MC0950.352-RS-260



## Framecontract for RTGs with

Specifications:



Company: Cargotec  
Place of usage: Finland  
Amount: Framecontract  
Type of crane: Rubber Tyred Gantry (RTG)  
Port environment

Travel length: 19,1 m  
Speed: 1,17 m/s  
Acceleration: 0,5 m/s<sup>2</sup>

Test RTG in Winter operation

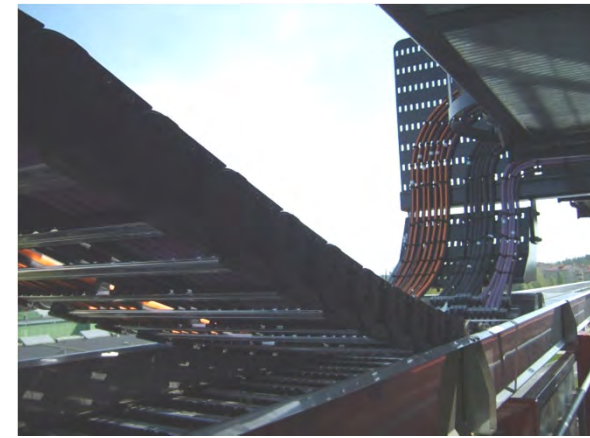

**RTGs for NIKMNOELL**  
SPECIAL CRANES

**Container Terminal Istanbul , Turkey**

Specifications:

Type of crane: 26 Rubber Tired Gantry Crane (RTG)  
Port environment  
Travel length: 18,40 m, center fixed point  
Speed: 1,17 m/s  
Acceleration: 0,3 m/s<sup>2</sup>  
Additional load: 10 kg/m  
Installation: 2000

KABELSCHLEPP MC 0950.429-RS/RM-260-10.545

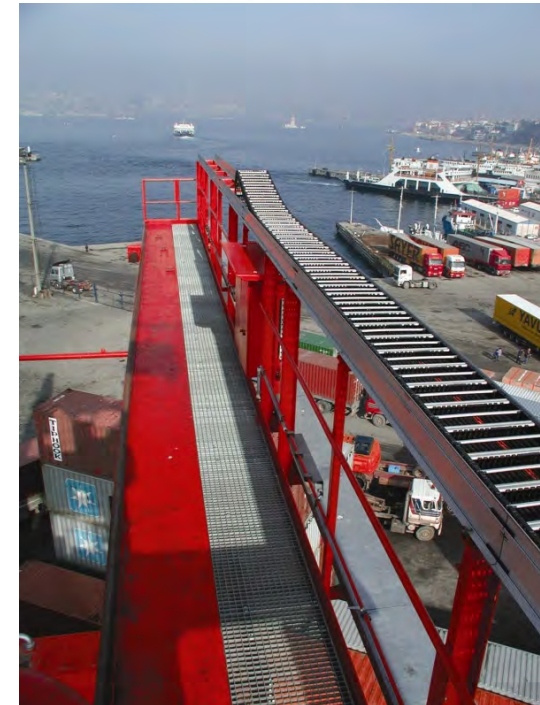

**CONTARGO®**

**STS for** ■■■ trimodal network

Specifications:

- Company: CONTARGO, Ludwigshafen
- Amount: 1 Set
- Type of crane: STS  
Inland port
- Travel length: 108 m
- Speed: 2 m/s
- Acceleration: 1 m/s<sup>2</sup>
- Additional load: 17 kg/m
- Installation:
- Cable carrier: MC1300.335-RMF-360-57200

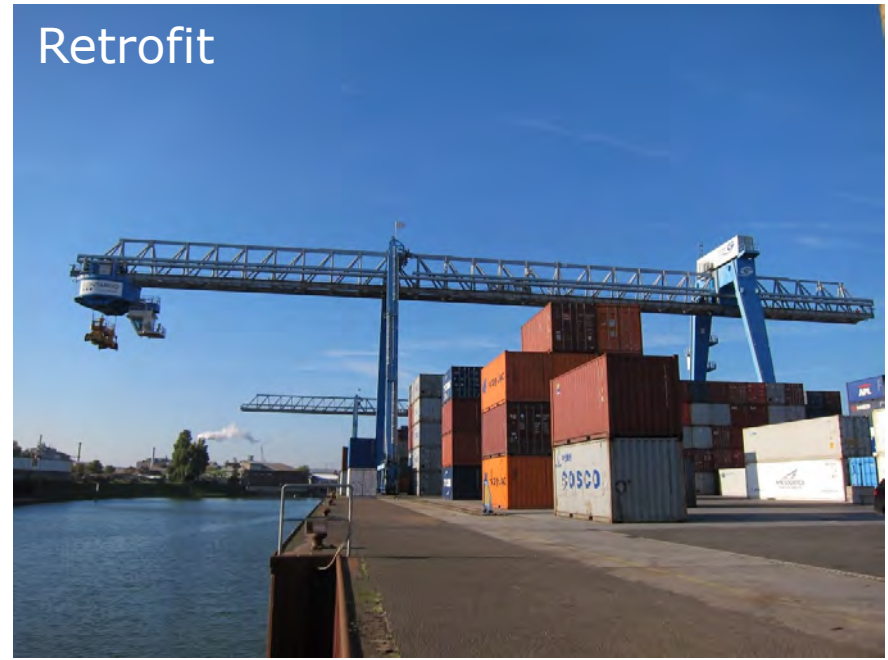

Retrofit

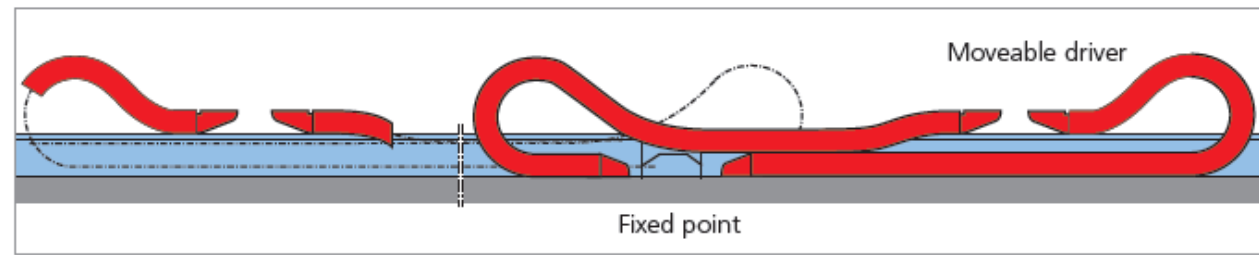

Opposing arrangement

## RMGs for **Liebherr Container Cranes Ltd.**

### Specifications:

Company:	Liebherr Container Cranes
Place of usage:	Vladivostok, Russia
Amount:	2 cranes
Type of crane:	RMG Crane
	Port environment, -40° C to +40° C
Travel length:	94 m
Speed:	2 m/s
Acceleration:	1,0 m/s <sup>2</sup>
Additional load	12,2 kg/m
Cable carrier:	MC1250.300-RM-260-50500

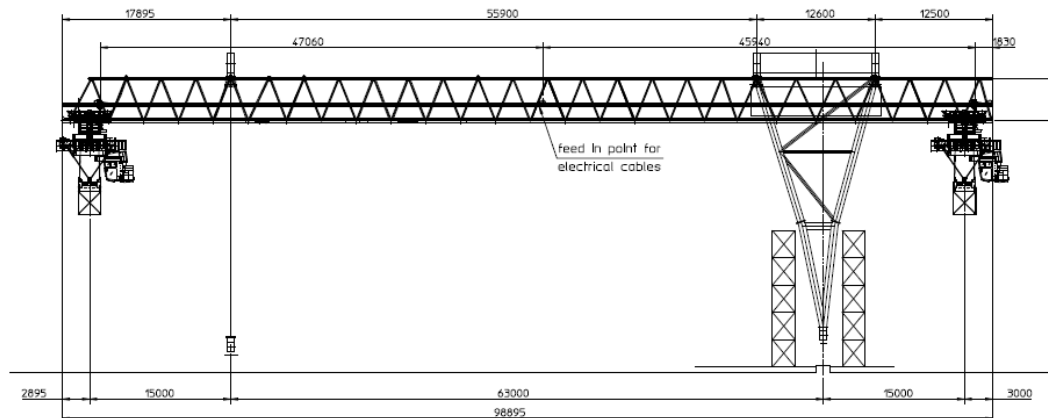



**RMG for Künz**

**Container Terminal Altenwerder (CTA), Germany**

Specifications:

Amount: 52 Sets  
Type of crane: Rail-Mounted Gantry Crane (RMG)  
Port environment

Travel length: 32,30 m  
Speed: 1,0 m/s  
Acceleration: 0,3 m/s<sup>2</sup>  
Opposite Arrangement  
Additional load 12 kg/m  
(divided among two carriers)  
Installation: 2001-2005

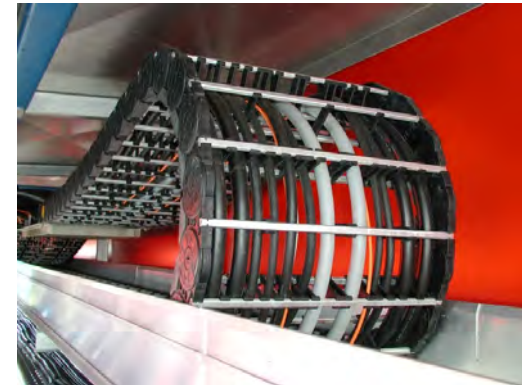

## **stx** Goliath Cranes

- STX Shipbuilding, Dalian (China)
- Feed for Upper und Lower Trolley
- Travel distance: approx. 250 m  
Additional load: max. 50 kg/m  
(distributed among two carriers)
- MC1300 with double-sidebands in opposing arrangement



- Cable carrier system for elevator.
- Close project management between Kabelschlepp India and Germany.

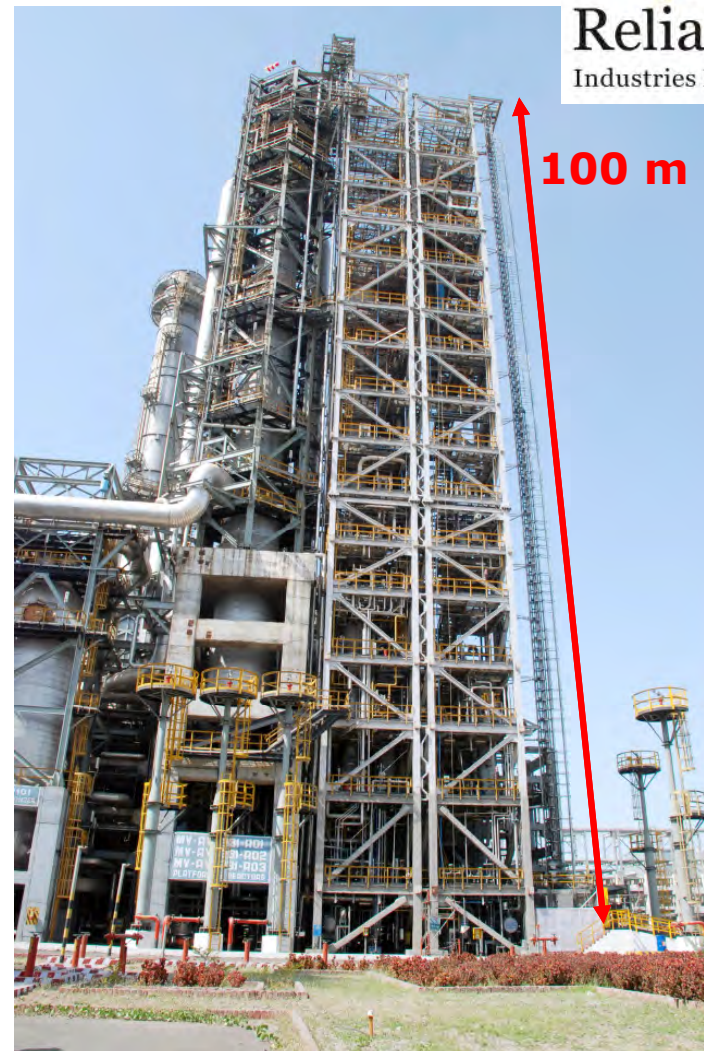
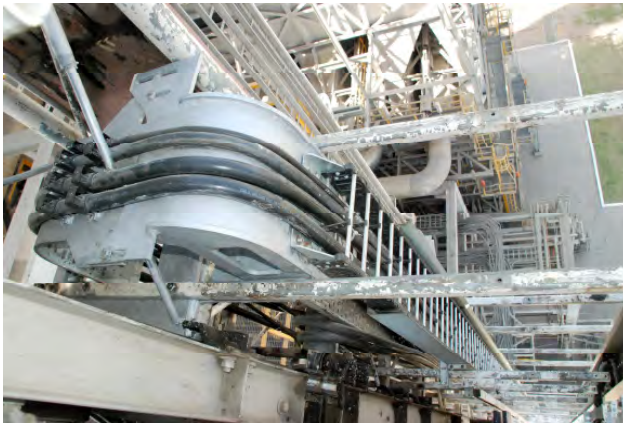

And many more.....





TSUBAKI KABELSCHLEPP

**Thank you**  
for your attention!