



Sure to be Safe



Sure to be Safe

Siegerland Bremsen

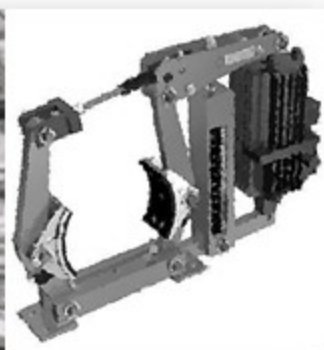

Siegerland

Bremsen





Sure to be Safe

Company ► Structure

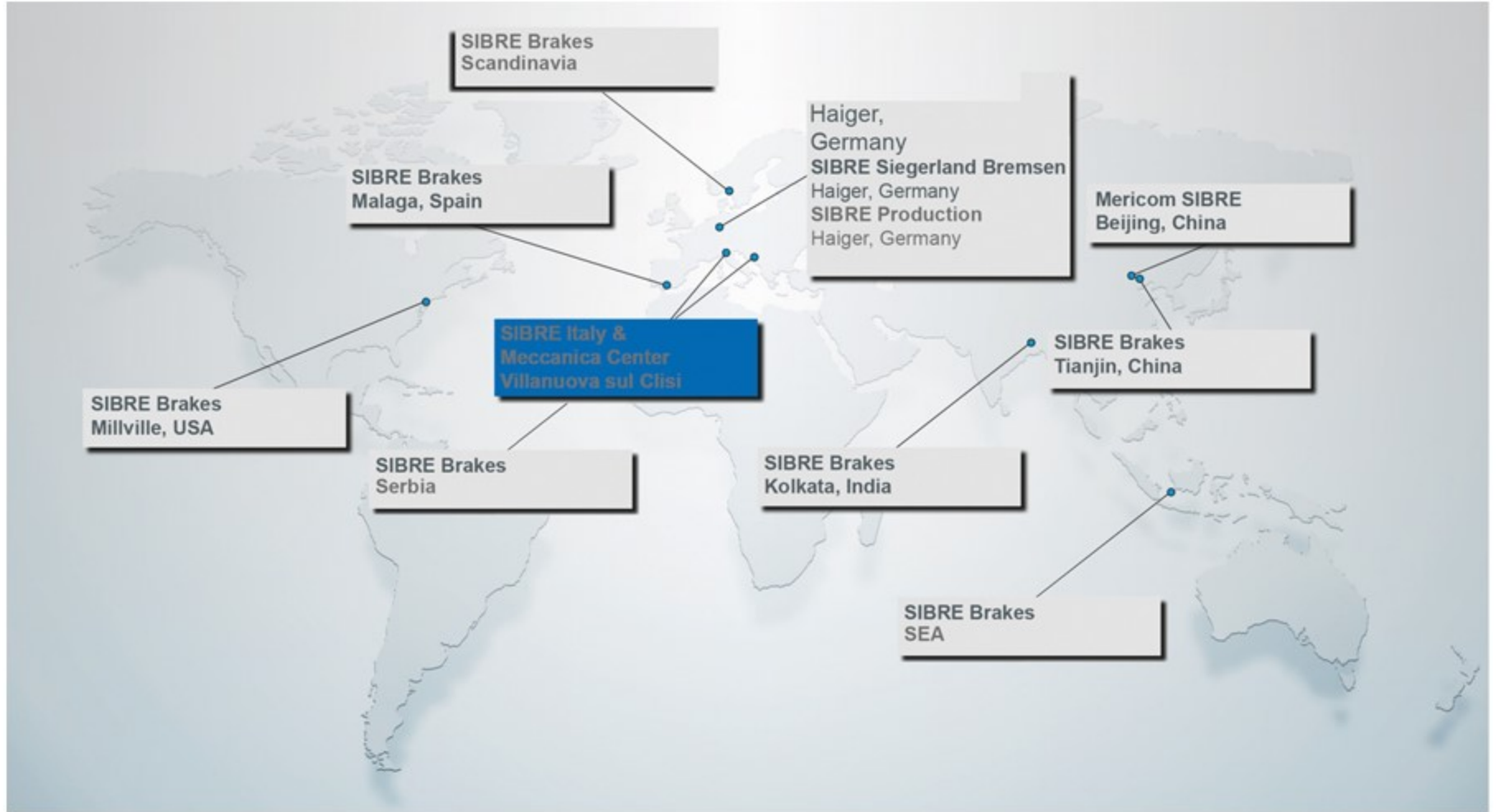

Established in 1958

Private Property

Head Office: Haiger, Germany

Manufactures:

- **Haiger, Germany**
- **Eschenburg, Germany**
- **Villanuova sul Clisi, Italy (assembling)**

200 employees approx.:

- Germany
- China
- India
- Spain
- Italy
- USA
- Australia

Agents and Partners in more than 50 countries.

Specialized in designing, manufacturing and distributing Industrial Brake Systems and Mechanical Drive Components



• 50s	1958:	Foundation of Siegerland Bremsen Emde GmbH & Co. KG. 4 employees in Haiger. Manufacture of non standardized drum brakes
• 60s	1963:	Beginning the manufacture of standardized drum brakes 7 employees – Extension of the production plant to 250 m ²
	1968:	Manufacture of drum brakes according to DIN 15435 Extension of the production plant to 1.000 m ²
• 70s	1976:	Manufacture of the first disc brake. Leadership in production of drum brakes according to DIN 15435 51 employees – Production area: 1.800 m ²
• 80s	1988:	Acquisition of the first CNC machine and CNC center
• 90s	1994:	Development of compact disc brakes SK2 and SK3
	1997:	Development of new USB 3 and SHI
• 2000	2000:	Development of twin caliper disc brake TEXU
	2008:	Incorporation of wheels to our range of products
• 2010	2011:	Incorporation of drum couplings, backstops and buffers to our range of products
	2013	Start of SIBRE Italy and development of drive components
	2014	Acquisition of 33% Meccanica Center
	2015	Acquisition of 50% Meccanica Center





Sure to be Safe

Company ► Why SIBRE?

<ul style="list-style-type: none">• Design, Development and Manufacture	<p>50 years developing brake systems with robust designs, compact dimensions, high torques and mechanizing with maximum precision and quality</p>
<ul style="list-style-type: none">• Support, advise and assistance	<p>Along the whole process -from initial design until commissioning at site- as well as maintenance works, trainings, etc</p>
	<p>Global, at every level: consultants, engineering, final client, manufactures, etc.</p>
	<p>Local service: presence in more than 50 countries</p>
<ul style="list-style-type: none">• Personalized solutions	<p>innovation, development and manufacture to cope clients' necessities, with personalized solutions to every application, sector and environmental conditions</p>
<ul style="list-style-type: none">• Guarantee	<ul style="list-style-type: none">▪ Maximum quality▪ Reliability▪ Minimum maintenance cost▪ Cycle life performance optimization▪ Competitive price▪ Superior operational uptime



Sure to be Safe

Range of products ▶ Applications





Boom hoist



Main hoist



Gantry

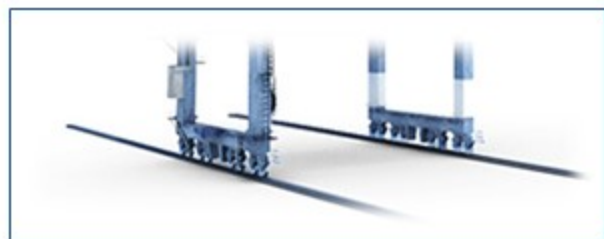

Trolley



Main hoist



SIBRE
solutions
for main hoist

Main hoist

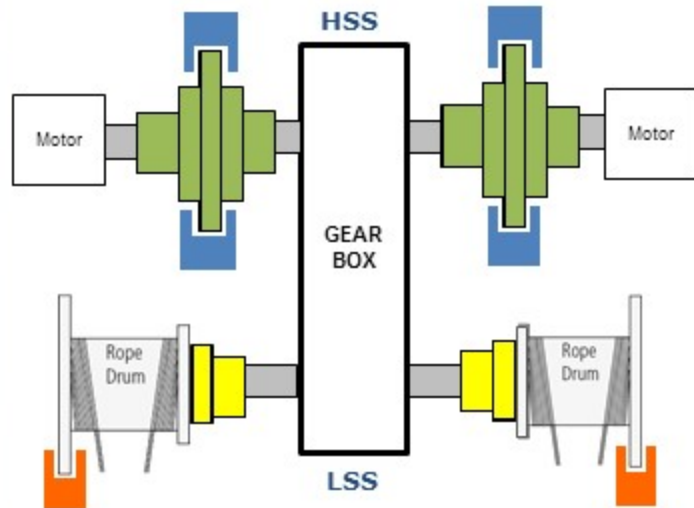

Service and Emergency brakes



Monitoring technology, Thrusters and HPU



Couplings



Rope sheaves, Ropes and Hooks



Boom hoist



**SIBRE
solutions
for boom hoist**

Boom hoist

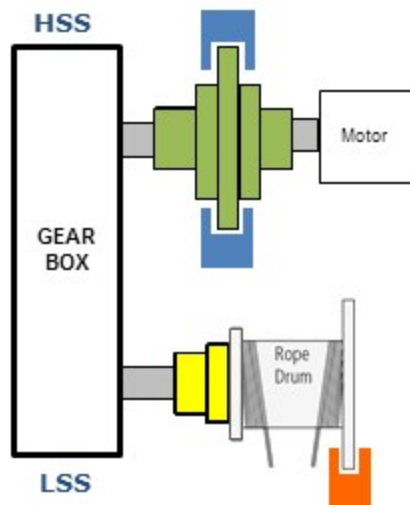

Service and Emergency brakes



Monitoring technology, Thrusters and HPU



Couplings



Rope sheaves



Trolley



SIBRE
solutions
for trolley

Trolley by motor (x4)

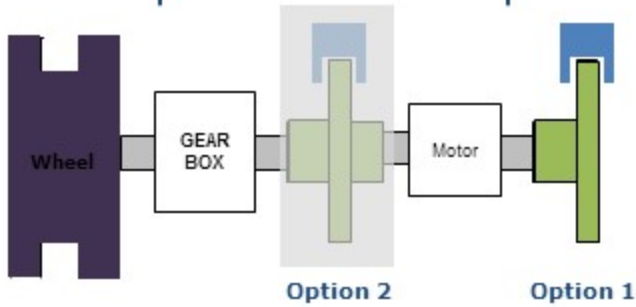

Service brakes



Monitoring technology and Thrusters



Couplings and Wheels

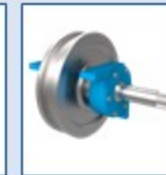

Buffers



Gantry

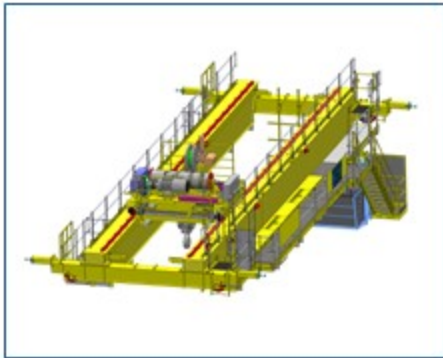

SIBRE
solutions
for gantry

Gantry Horizontal shaft

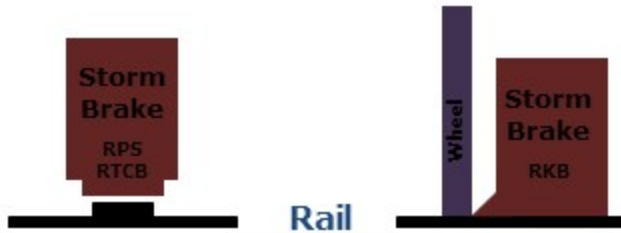
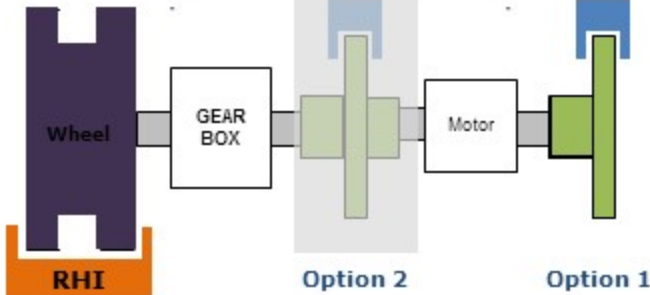

Service brakes



Storm brakes

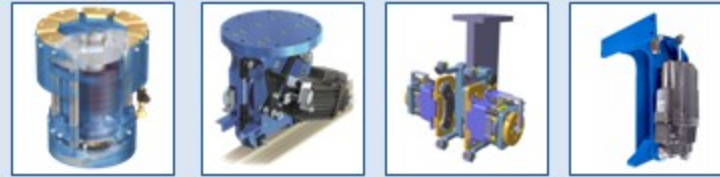

Monitoring technology, Thrusters and HPU



Couplings, Wheels and Buffers



B
R
A
K
E
S

Service and Emergency brakes

Disc- and Shoe Brakes mounted on high/low speed shaft



USB



TEXU



CB8



TE



SHI



RPS



RTCB



RKB

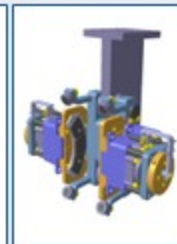

RHI

Storm brakes

O
T
H
E
R
S

Other components



Couplings



Over speed
Limit switch



Drum
couplings



Wheels



Buffers



Rope
Sheaves



Hydraulic
Power Units



Thrusters
EB/ED



Ropes and
hooks

Range of products ► Main brakes



USB



TEXU



SHI



TE



CB8

	USB	TEXU	SHI	TE	CB8
Type	Disc	Disc - Twin Caliper -	Disc - Caliper-	Drum	Disc - Compact-
Application	Service	Service	Emergency	Service	Service
Thruster	Electro-hydraulic Electro-magnetic	Electro-hydraulic	Hydraulic	Electro-hydraulic Electro-magnetic Hydraulic Pneumatic	Electro-hydraulic Electro-magnetic Hydraulic Pneumatic
General features			[Clamping force]		
<i>Braking torque</i>	600Nm - 32.000Nm	3.000Nm - 30.000Nm	4,3kN - 440kN	50Nm - 8.200Nm	250Nm - 9.000Nm
<i>Lining</i>	Sinter	Sinter	Sinter	Organic	Organic & Sinter
<i>Wear compensator</i>	Yes	Yes		Yes	Yes
<i>Synchro-linkage</i>	Yes	Yes		Yes	
<i>Manual release and sensors</i>	Yes	Yes	Yes	Yes	Yes





Sure to be Safe

Range of products ► SIBRE SMART



MONITORING	ANALYSIS	REMOTE	TECHNOLOGY
<ul style="list-style-type: none"> ▪ Brake status ▪ Brake/crane/port/world view ▪ Multi-platform monitoring from anywhere in the world 	<ul style="list-style-type: none"> ▪ Statistics ▪ Reports ▪ Alarms & Actions ▪ Maintenance guide 	<ul style="list-style-type: none"> ▪ 24/365 ▪ One single monitor per crane ▪ Web remote access ▪ Sibre remote service ▪ Sibre help desk 	<ul style="list-style-type: none"> ▪ Full range of brakes sensors ▪ SMART acquisition sensors through Sibre bus. ▪ Capacity touch monitor ▪ High availability & Secure Data Center ▪ TSL/VPN data transfer ▪ Bypass sensor signals to keep crane operation

Customer 	Productivity
	Safety
	Control

- Supervise brake equipment with less staff
- Preventive action
- Reduce unplanned downtime
- Optimize the deployment of maintenance teams
- User brake friendly
- Clearly presented maintenance manuals
- Shorten your response time in case of dysfunction

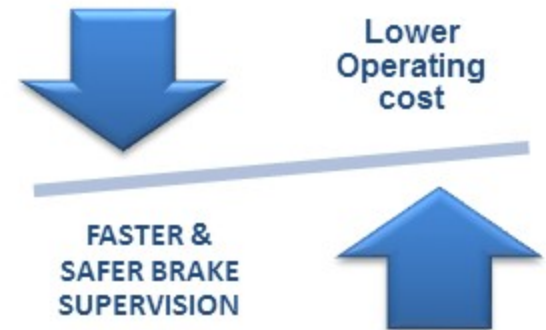



S L P

Snag Load Protection



Sure to be Safe

Range of products ▶ SLP

WHAT IS SNAG?

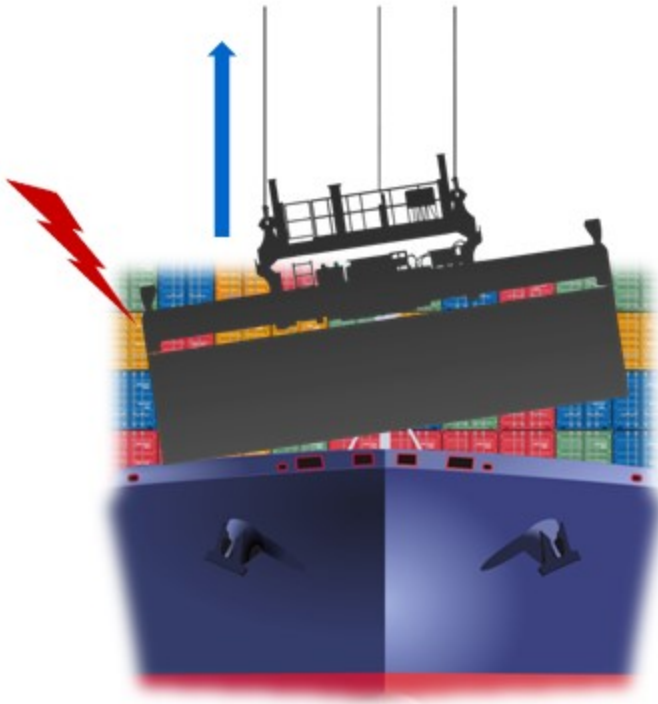

Snag & twisting of the container when being lifted out of the cargo deck

Worst scenario

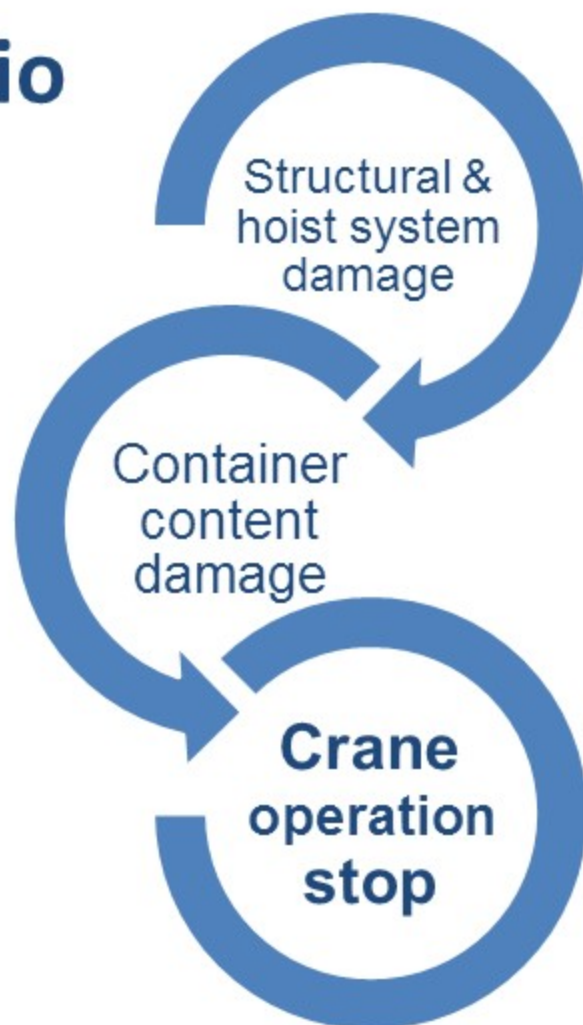

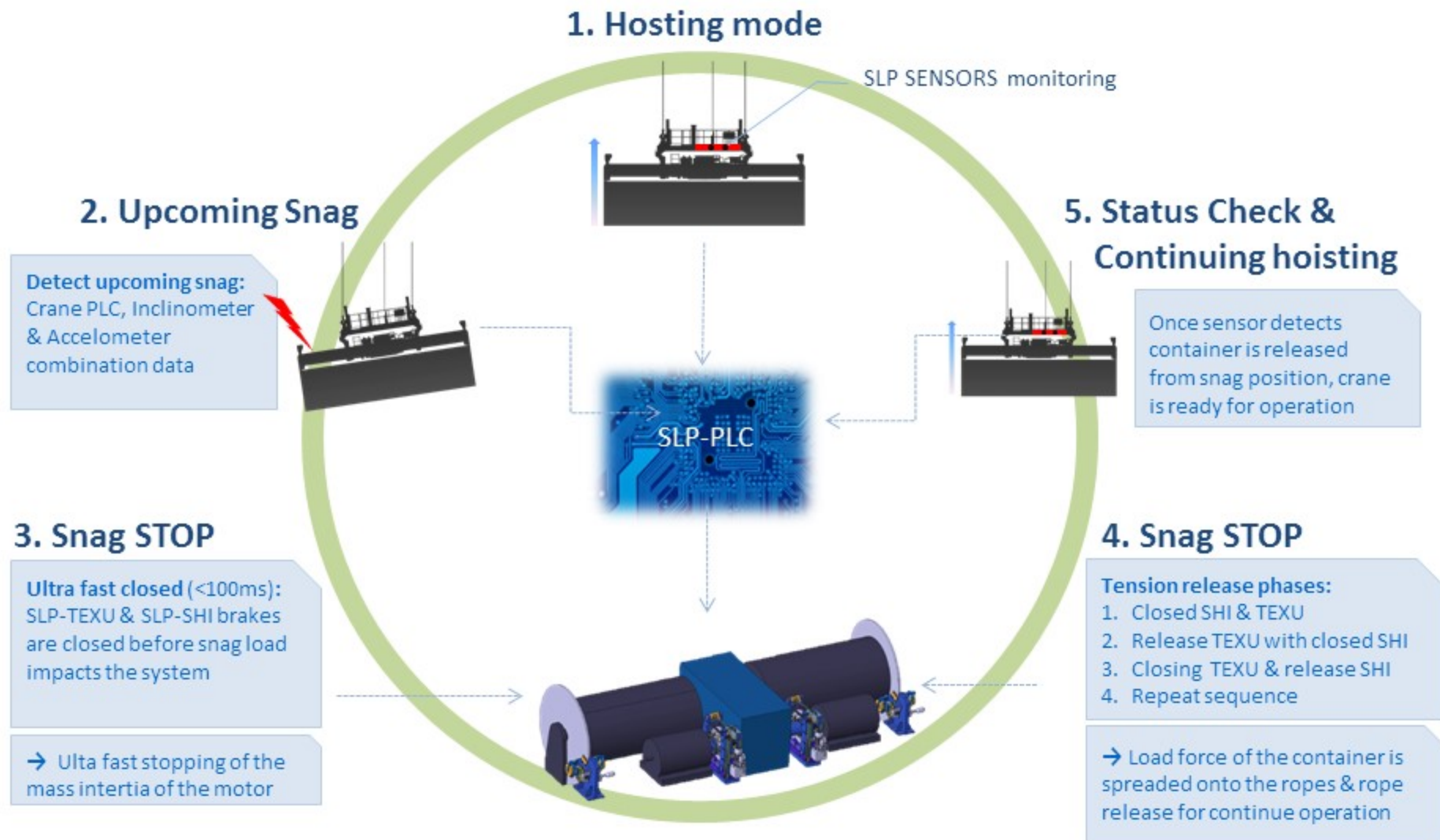



Sure to be Safe

Thanks for your attention!



Sure to be Safe