



# Brake Technology and Monitoring for Increasing Safety and Productivity

Maik Zielberg, Technical Sales



Siegerland Bremsen

### SIBRE Holding GmbH & Co KG

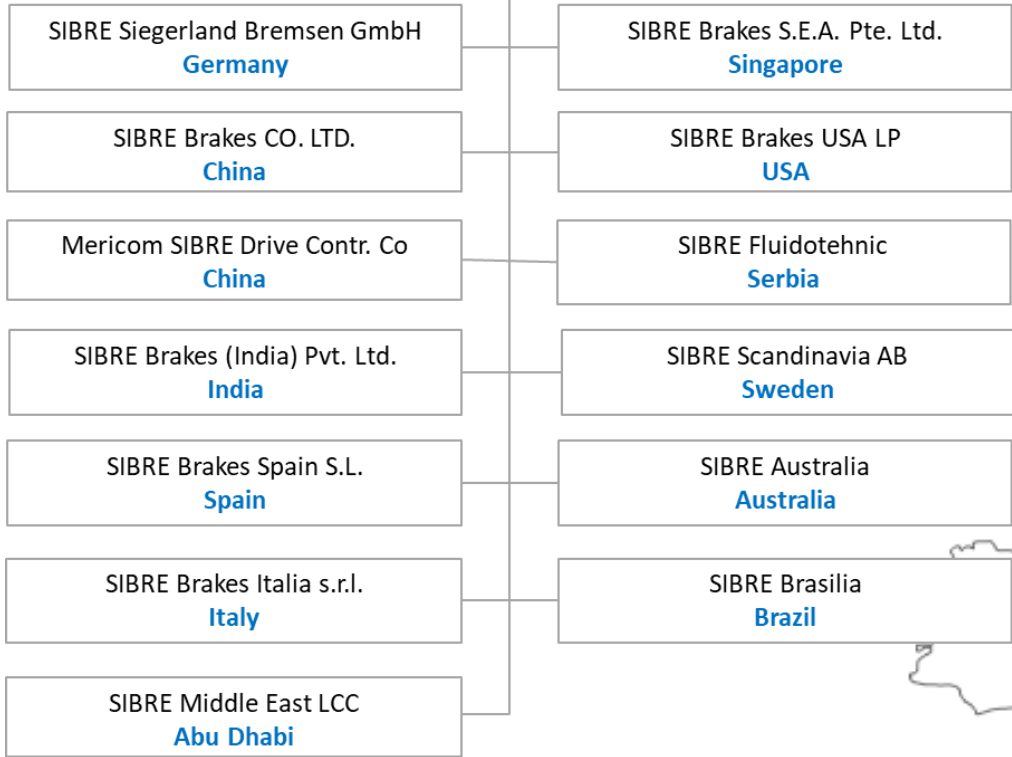

# Designed, tested & manufactured in Germany

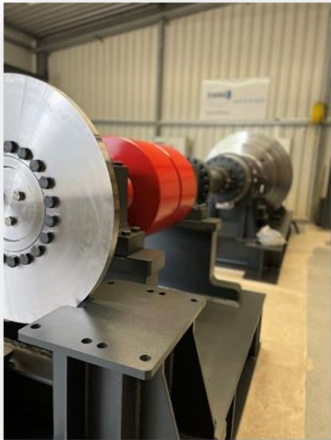
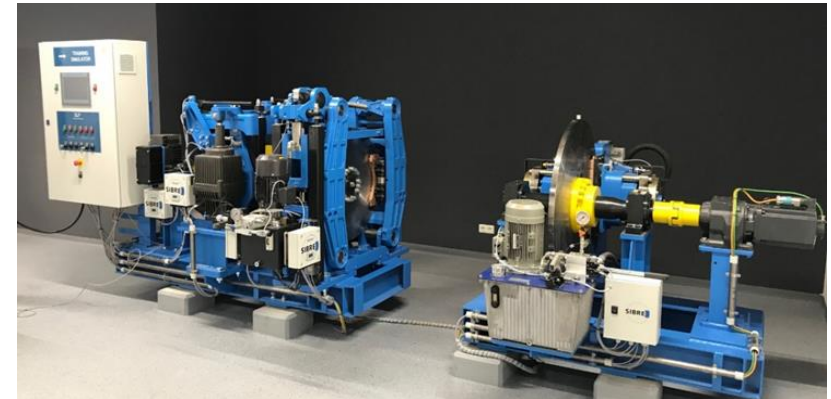
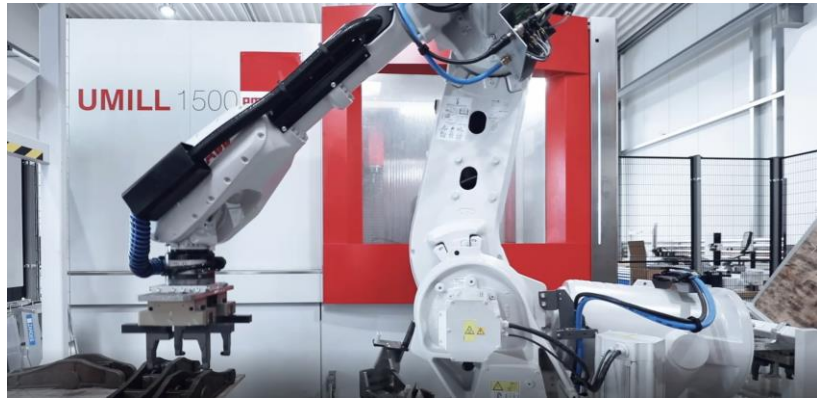

AS A ONE STOP SUPPLIER, SIBRE  
DELIVERES COMPREHENSIVE  
SOLUTIONS FOR ALL DRIVES IN CRANES.

SERVICE-BRAKES

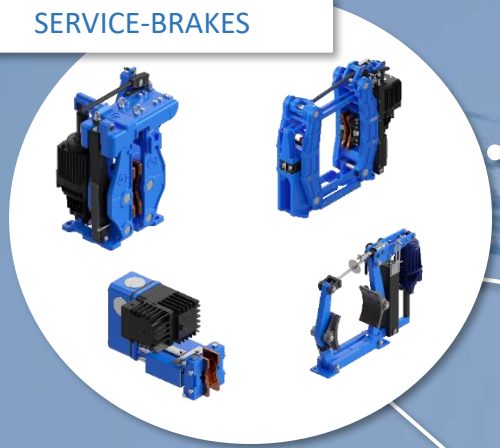

SAFETY-BRAKES

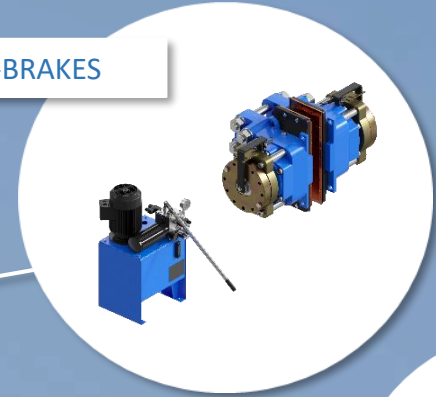

SNAG LOAD PROTECTION & MONITORING



STORM-BRAKES



WHEELS & SHEAVES

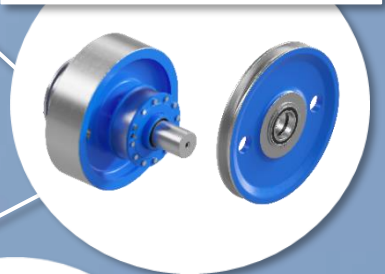

HYDRAULIC BUFFER

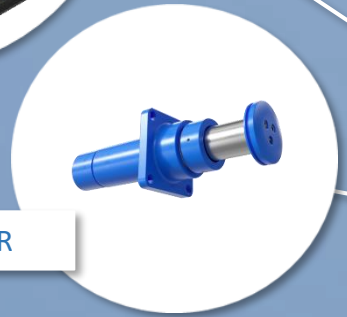

COUPLINGS



# USB5 service brake - key design advantages

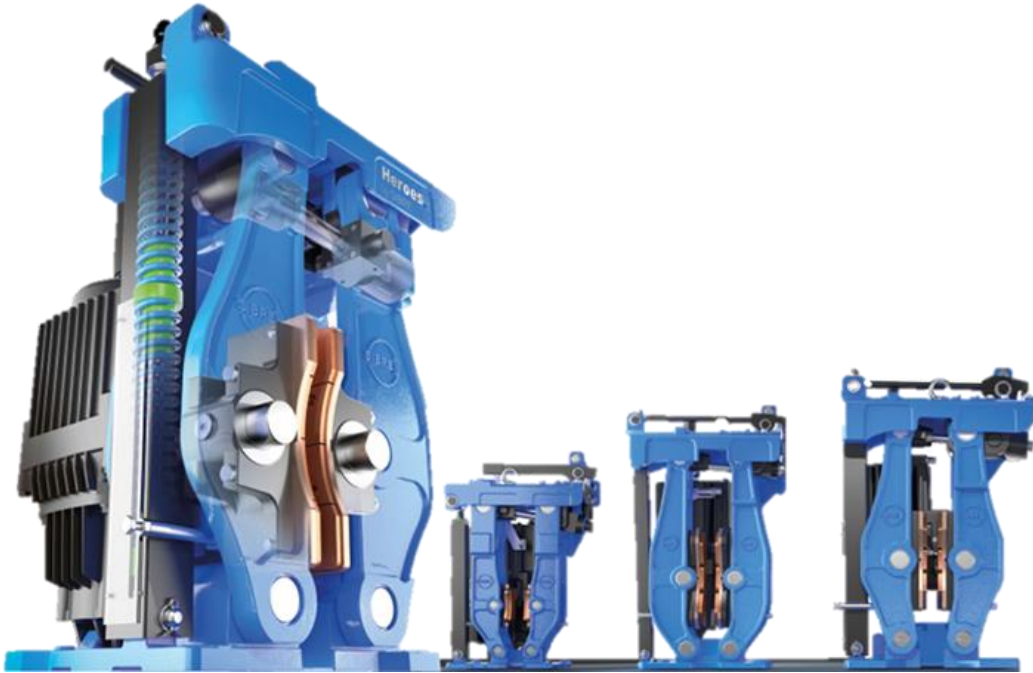

- Designed for all applications in a crane
- Identical conditions regarding installation, adjustment and maintenance
- Enhanced corrosion protection
- Parallel opening of brake shoes
- Optimized spring unit
- Upgraded manual release system



# SHI emergency brake – key design advantages

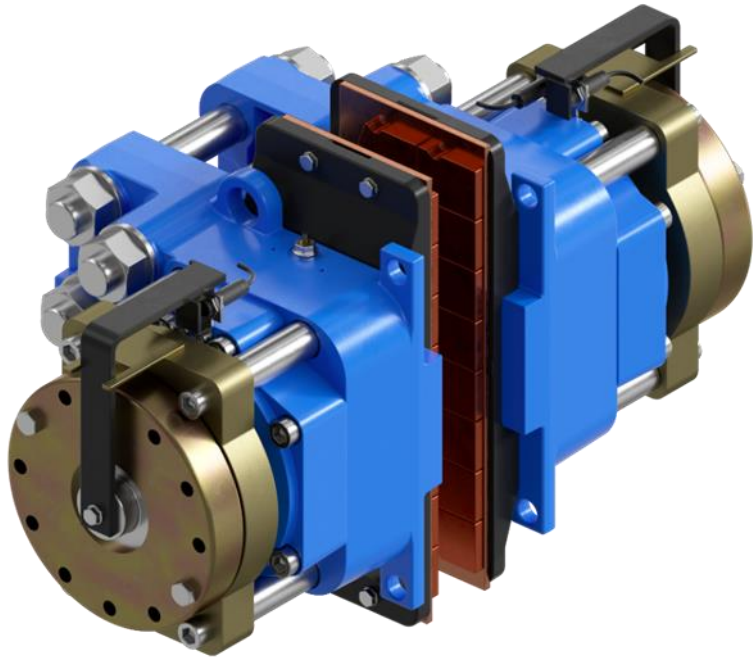

- Less leakage-risk
- Less maintenance requirements
- Favorable force-transmission

- 1) Extending cup-springs
- 2) Transmission to piston
- 3) Transmission to pressure pins
- 4) Transmission to linings/disc

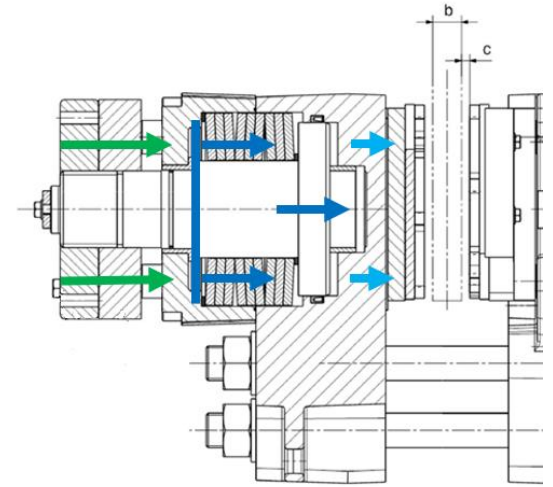

# SIBRE new developments

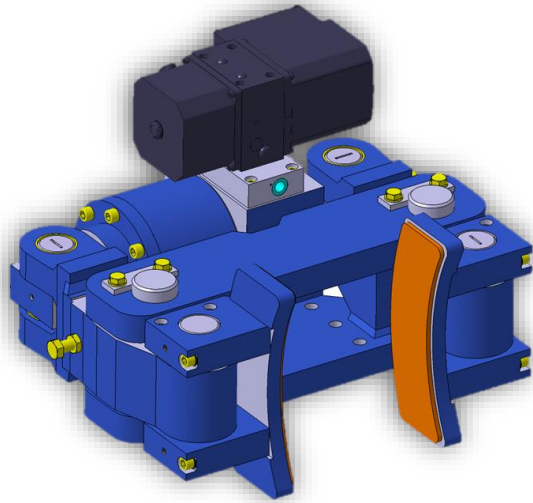

## **RHI face lift**

Casted version  
Braking forces up to 120 kN  
available with at side HPU

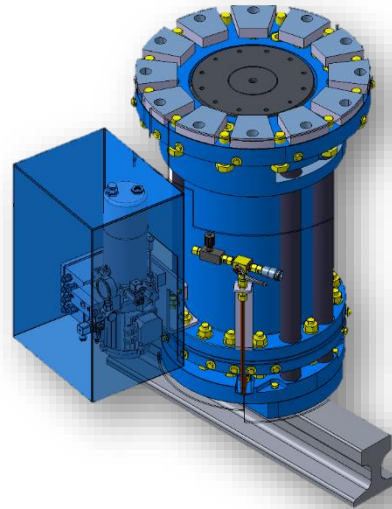

## **RPS with HPU at side**

No piping along the bogie  
Reduction of opening time

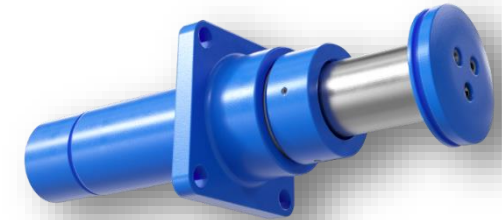

## **New buffer series SP**

Forces up to 700 kN  
Strokes up to 1200 mm



# SLP snag load protection

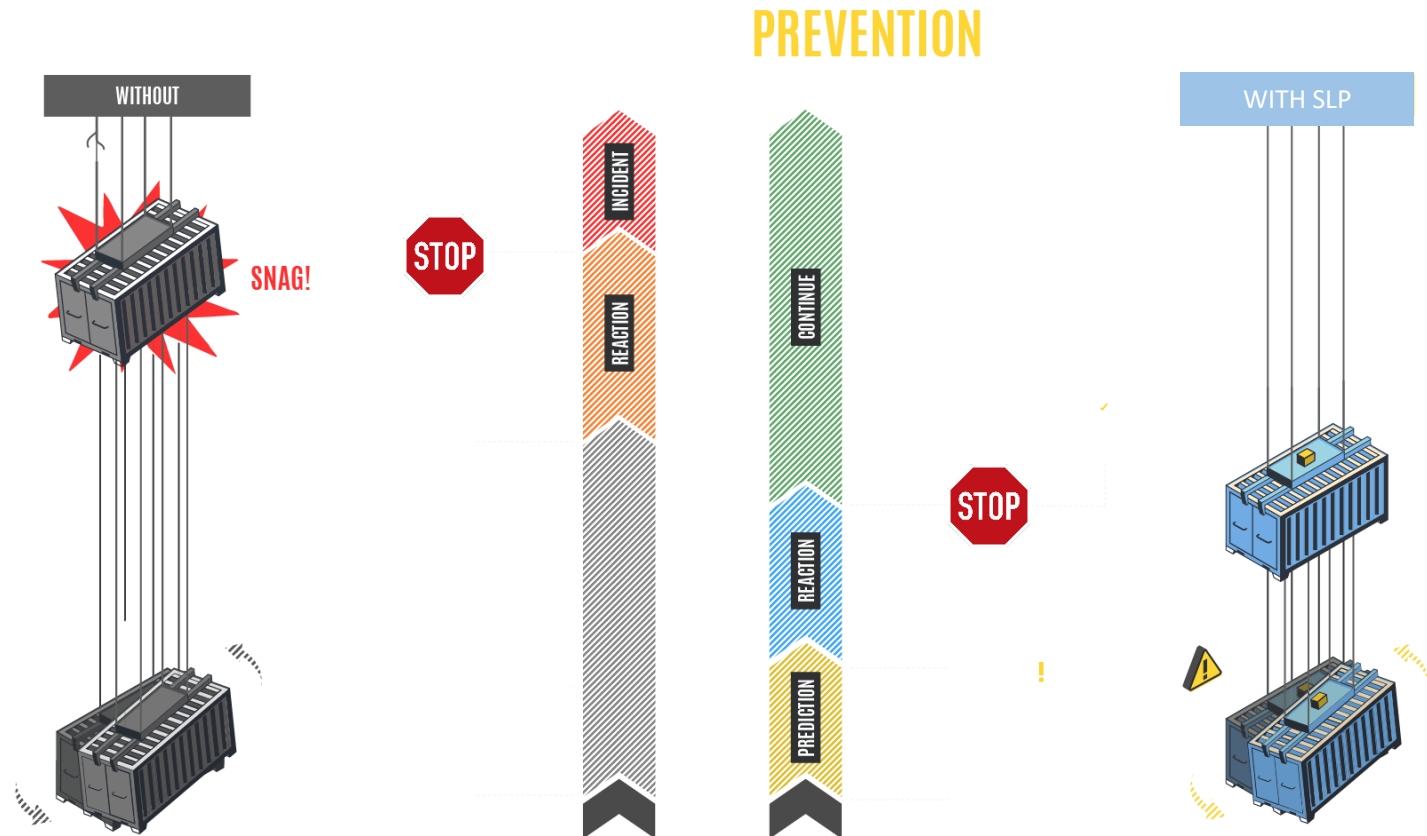



# Maximize your efficiency by

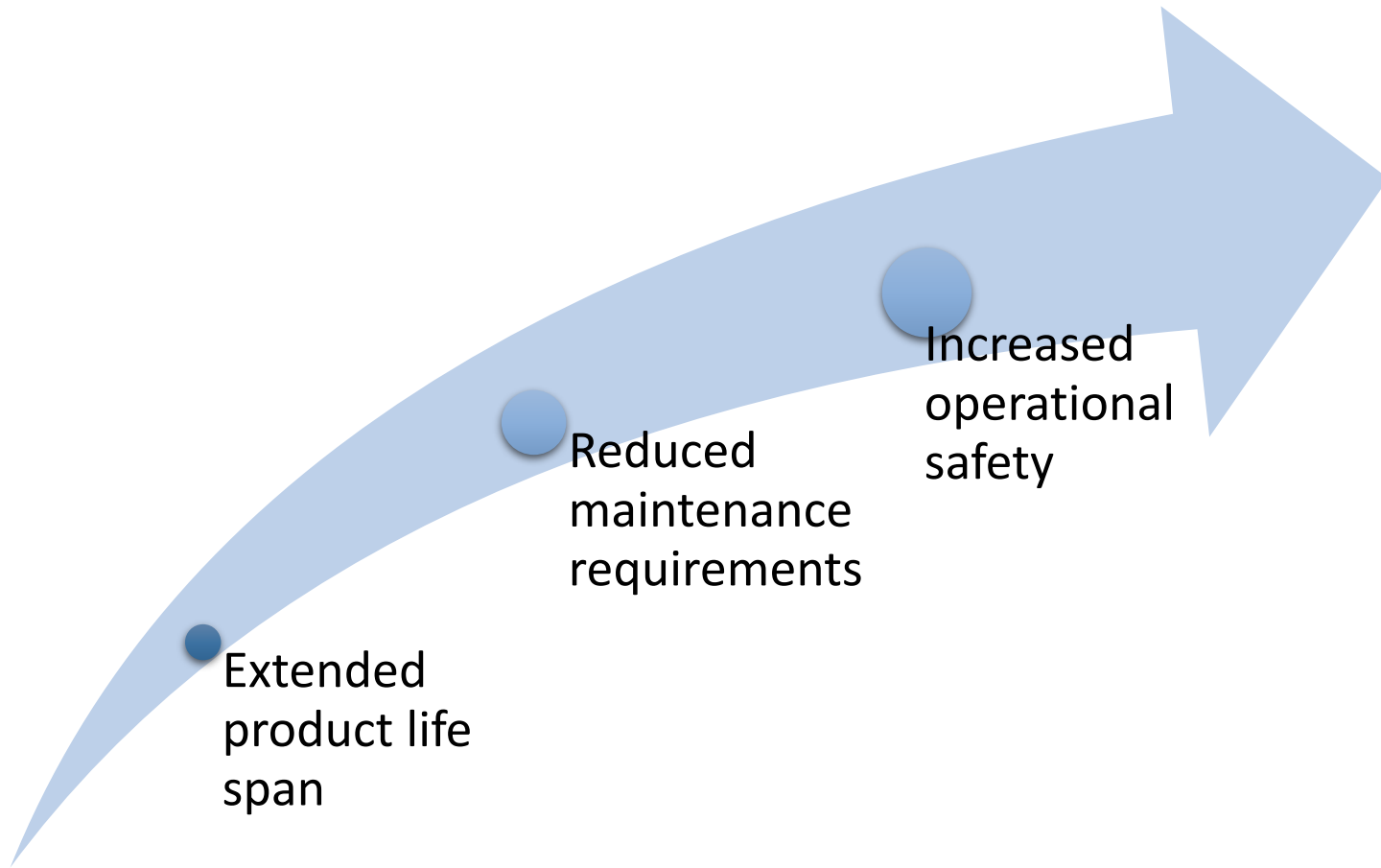

Questions? Visit us at stand 10



*Sure to be Safe*

Siegerland Bremsen



**Black and  
Caspian Sea 2023**

**PORTS & SHIPPING**

Thank you for your attention!

[mz@sibre.de](mailto:mz@sibre.de) | [www.sibre.de](http://www.sibre.de)

