



Next Generation of Port Cranes, Hybrid and Full Electric

September 2023

LIEBHERR

Maritime Cranes

Maritime Products

By Liebherr







Mobile Harbour Cranes

- Mobility : travelling on tires or on rail
- Versatility : containers, bulk, general cargo
- Originally powered by diesels engine

Next Generation of Port Cranes, Hybrid and Full Electric

01 Electro – Hydraulic Drive

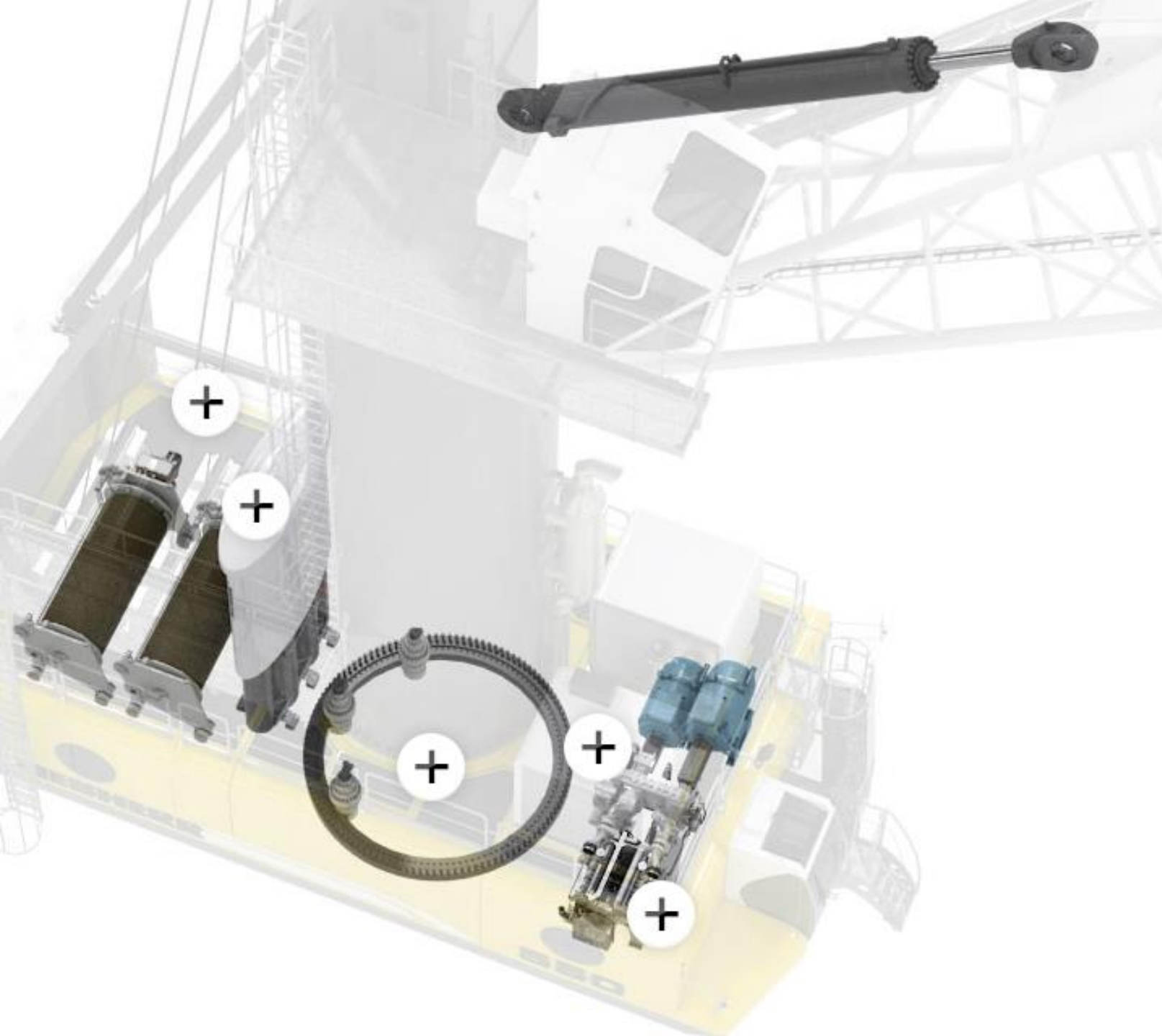

Electro - Hydraulic drive concept

- Prime mover : electric motor
- Connected to a splitted gearbox
- Pumps and hydraulic motors
- Hoisting, slewing, travelling

Electro – Hydraulic

- For emission free operations
- Liebherr mobile harbour cranes are able to operate emission free for 25 years
- When an on-shore power supply is available
- From low to high voltage with a cable drum



E-Drive sales figures

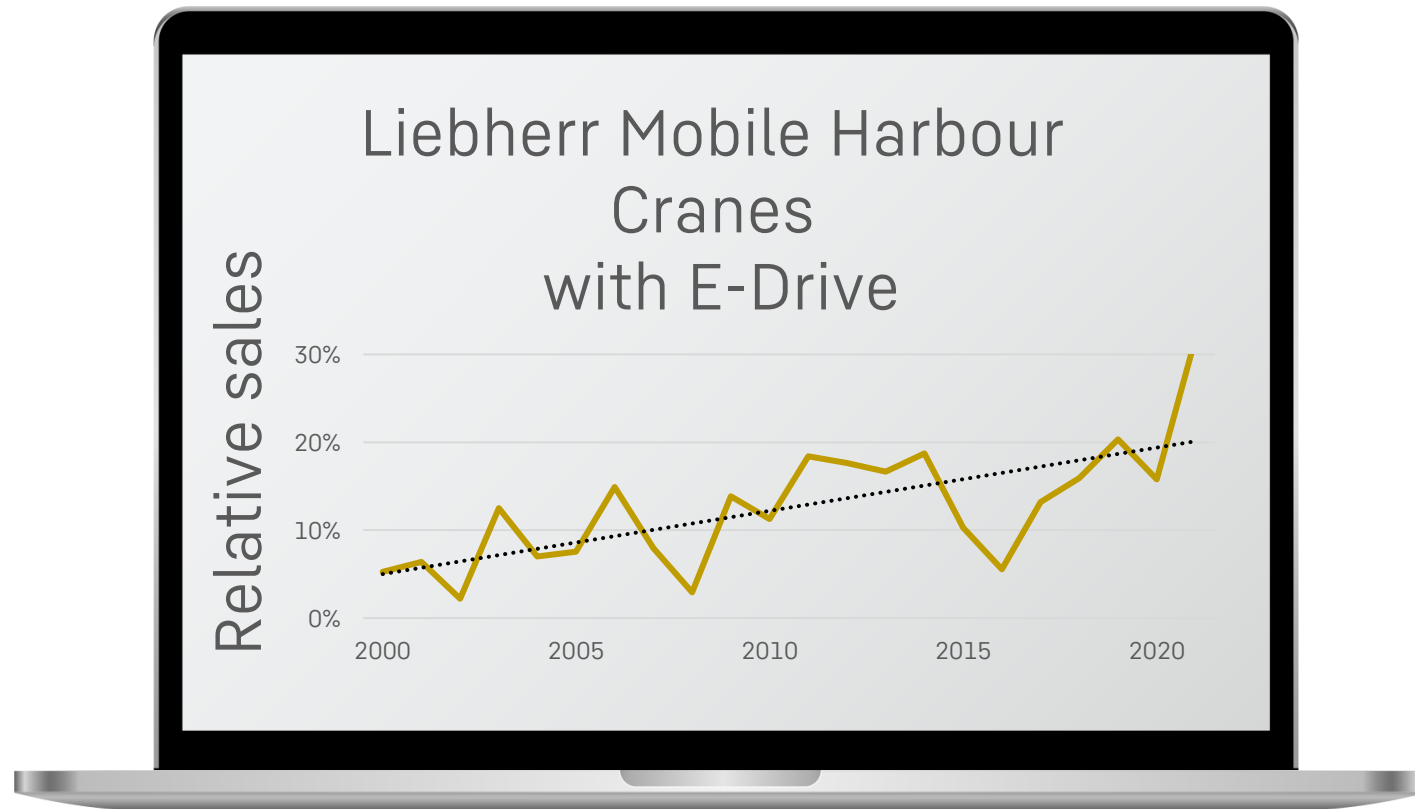

In 2022: 30 % of mobile harbour cranes delivered are e-driven.

02

Synthetic fuel





Synthetic fuel HVO 100

- Hydrotreated Vegetable Oil
- Made of 100% renewable raw materials
- Premium quality fuel with a chemical structure almost identical to regular diesel
- 90% less CO₂ emission
- Port of Södertälje (Sweden) runs the first Liebherr mobile harbour crane with HVO 100

03

PACTRONIC: Hybrid drive system





Pactronic® 2.0

- The Liebherr Pactronic is a power-booster
- Power by accumulator and electronics
- Contribute to crane operation efficiency

Hybrid technology

Pactronic 2.0

BOOST MODE

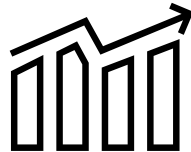

Increased hoisting power (+100%)

Higher turnover with efficiency

Handling performance (+30%)

GREEN MODE

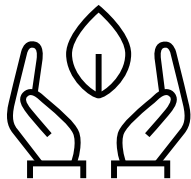

Reduced energy consumption

Reduced CO2 emissions



05

Battery for travelling mode





Unplugged LHM

- 264 kWh battery capacity
- Up to 2 km travelling distance
- Fully recharged battery 10-12h
- 10 years battery lifetime
- Emergency operation possible
- Retrofit possible on older LHM

06

Fully electric crane





LPS 420 E

First 100% electrical driven port crane in the Liebherr Mobile Harbour Crane product range

All crane movements electrically driven:

- Luffing
- Hoisting
- Slewing
- Driving

Thank you.



LIEBHERR