

STEMMANN-TECHNIK

A Wabtec subsidiary



Alternative Maritime Power Systems

Daiei Hoffmans, International Sales Manager

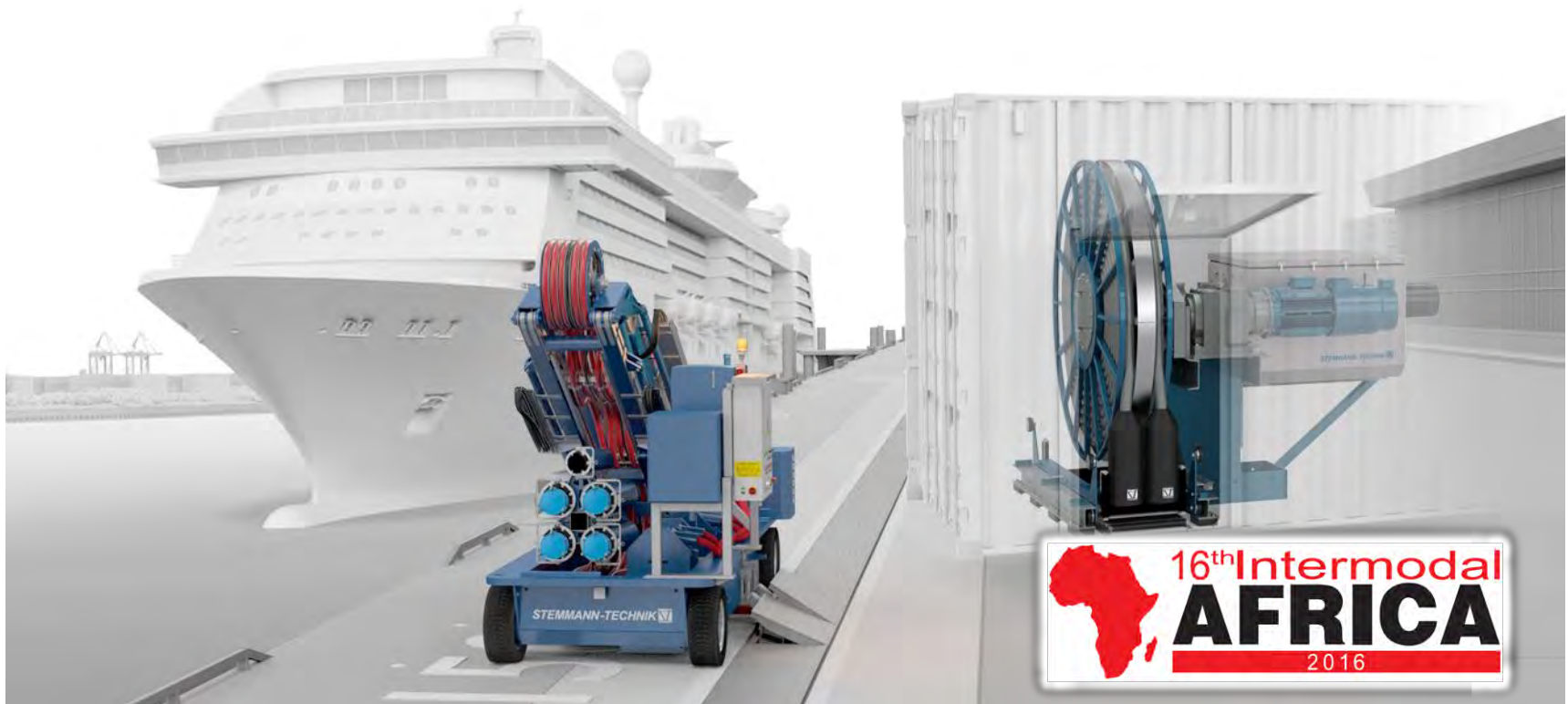



Onshore Power Supply & Charging Systems

Reduction of Emissions in Ports



The emissions caused in the port area are a growing problem due to the increasing capacities of the ports.

The onshore power supply units will replace the diesel-powered vessel generators to a large extent.

The implementation of emission limit values and environmental specifications in general expedite this development.





Onshore Power Supply & Charging Systems

Various Solutions for...

Container Vessels

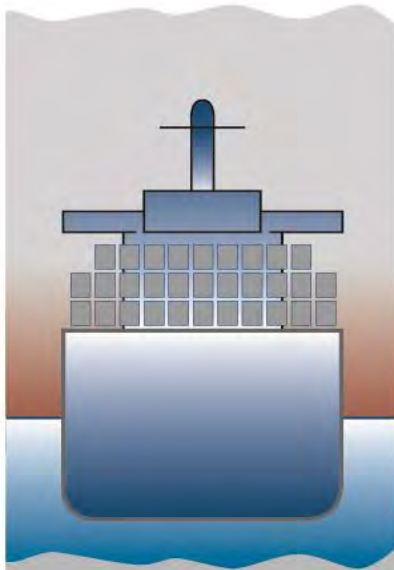

Onshore Power Supply via Cable Reel Container System

Cruise Liner

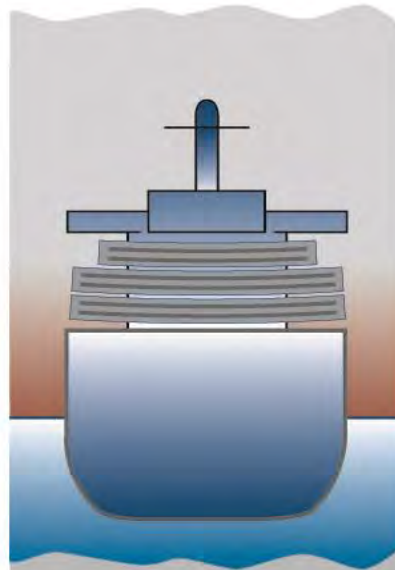

Onshore Power Supply via Cable Reel / Mobile Carrier System

Electrical Ferries

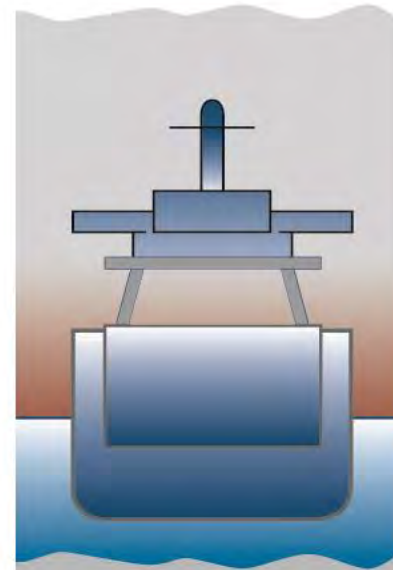

Quick Charging Connection via Pantograph System

Yachts

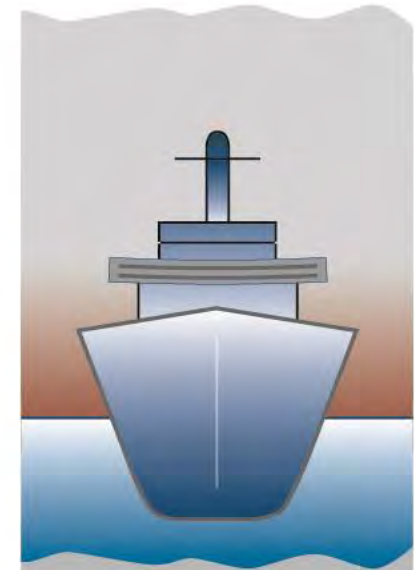

Special Applications via Cable Reel System



Onshore Power Supply for Container Vessels

Onshore Power Supply via Cable Reel Container Systems

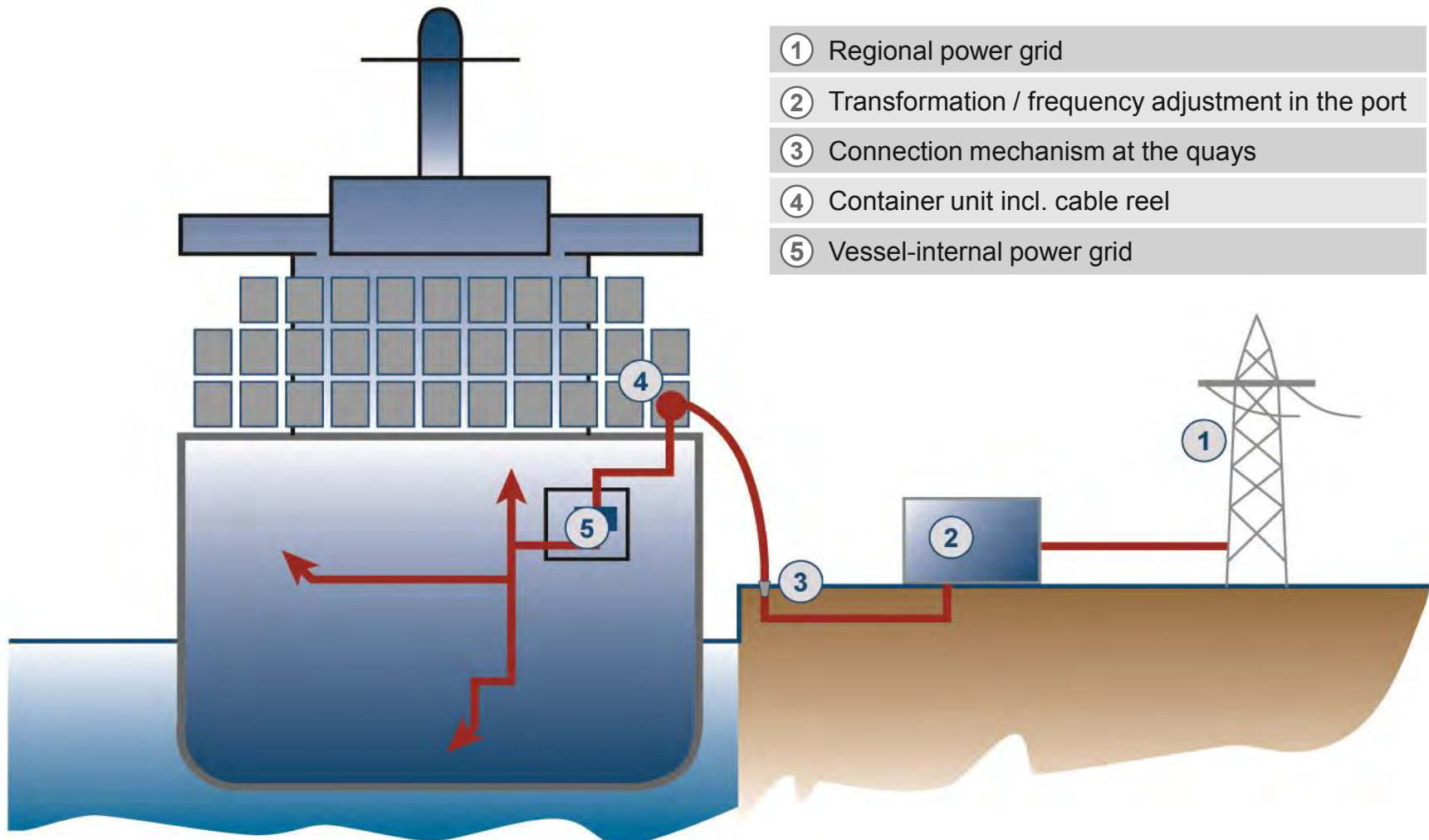



Onshore Power Supply for Container Vessels

Onshore Power Supply via Cable Reel Container Systems

Onboard System





Onshore Power Supply for Container Vessels

Onshore Power Supply via Cable Reel Container Systems



The feed of the onshore power supply for container vessels is realised for example by the installation of a 40 ft. HC-container in the bottom storage row.

The system consists of a spiral cable reel with slip ring assembly and fibre optic rotary connector incl. the drives for the reel and the extension system of the roller conveyer.



Onshore Power Supply for Container Vessels

Onshore Power Supply via Cable Reel Container Systems

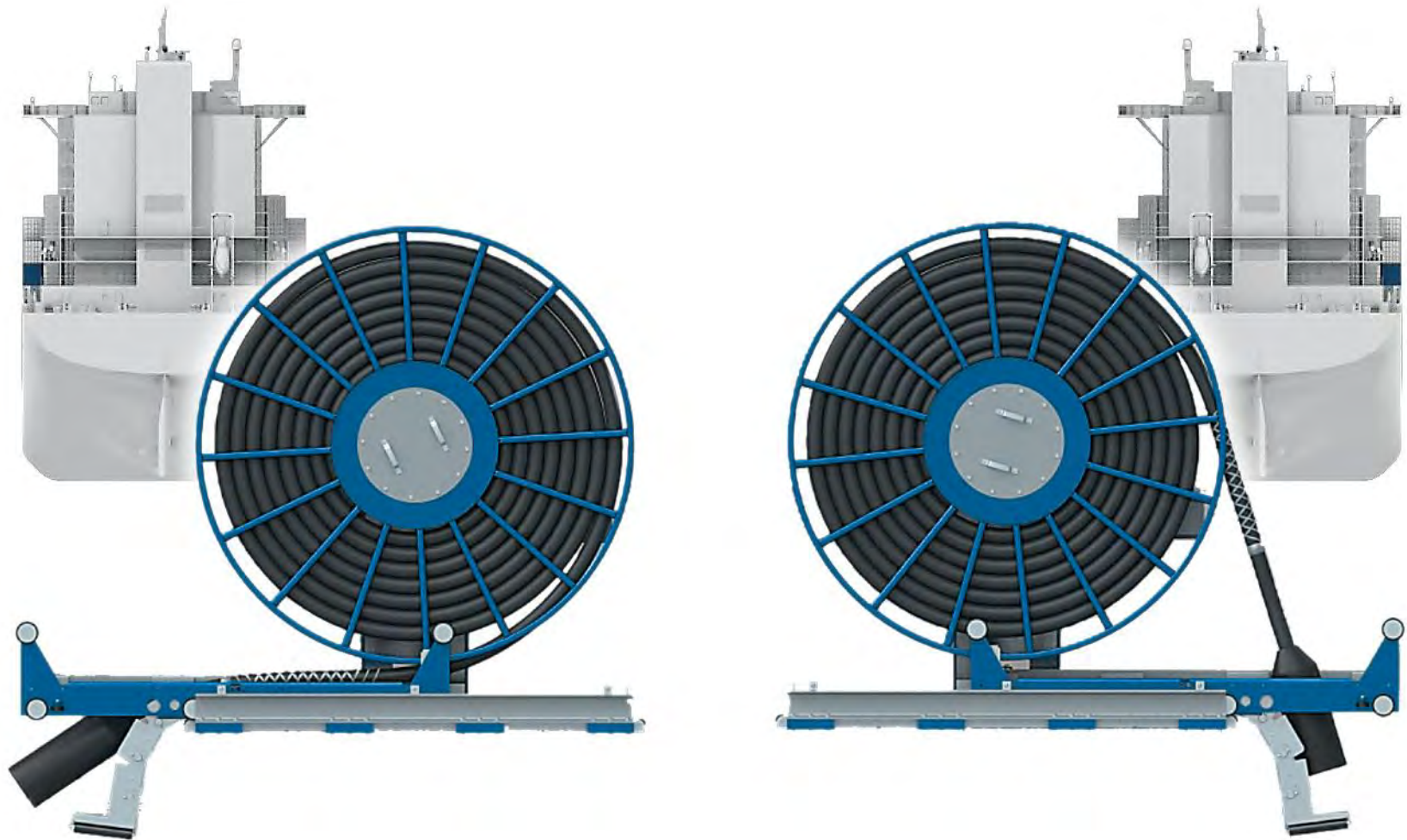



Onshore Power Supply for Container Vessels

Onshore Power Supply via Cable Reel / Mobile Socket System

Onshore System



Combination of HC-container installation on board and mobile socket installation onshore.

Flexible mounting heights depending on the local conditions.

Flexible traveling lengths depending on the local conditions.

Onshore Power Supply for Container Vessels

Onshore Power Supply via Mobile Socket Systems

Onshore System

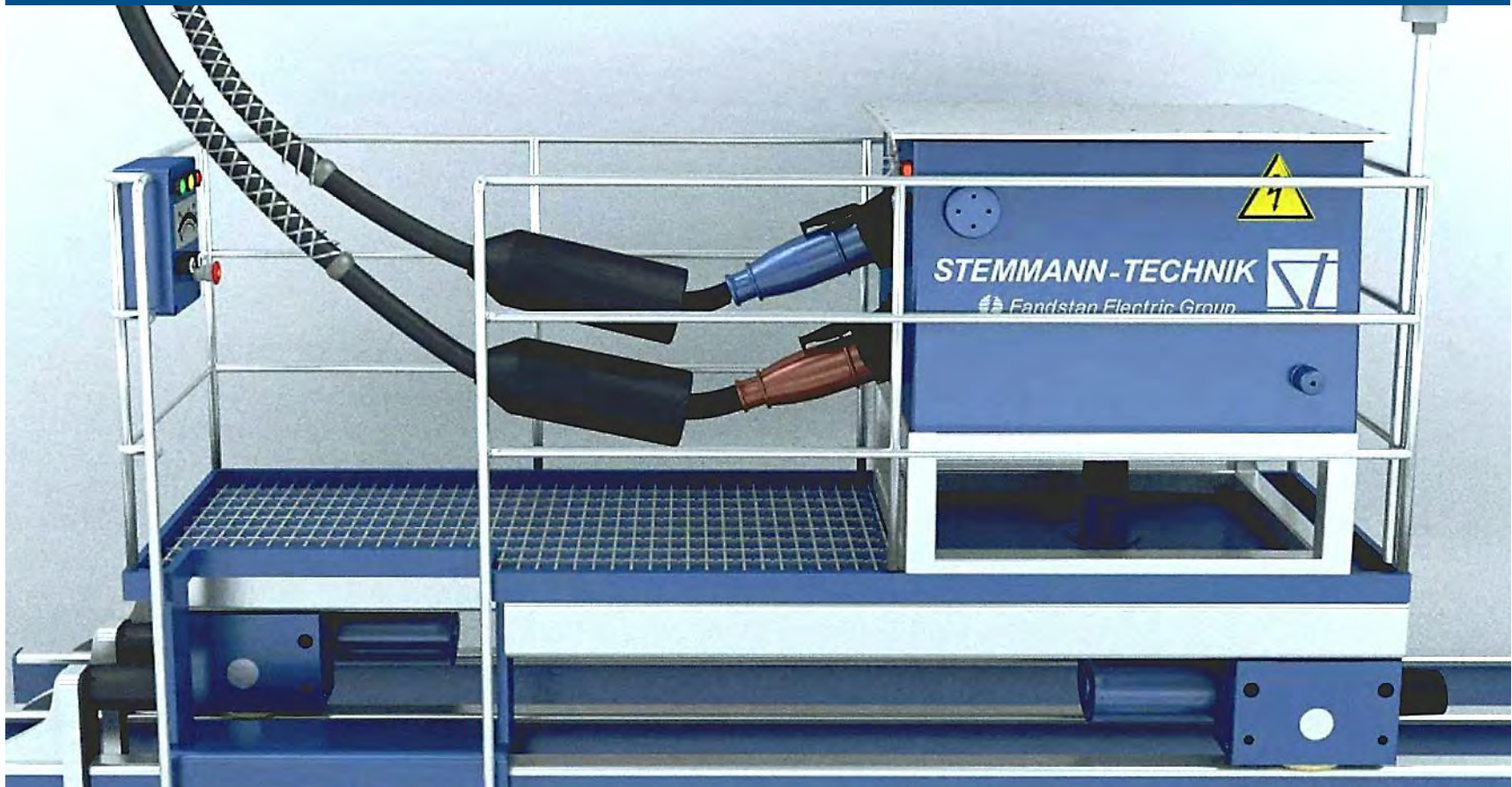



Onshore Power Supply for Container Vessels

Container System Advantages



HC-container installation in the bottom storage row requires no special housing installation on board.

Installation/cable pay-off on port- or starboard side possible.

Constant tension on cable by torque motor.

Excess tension-coupling for protection from damage to the mechanical parts.

The operation is effected by means of a radio remote control.

Decades of experience in the construction and manufacturing of cable reels.



Onshore Power Supply for Cruise Liner

Onshore Power Supply via Mobile Carrier Systems

Onshore System





Onshore Power Supply for Cruise Liner

Vehicle in Action



Onshore Power Supply for Cruise Liner

History of the "SAMP Hamburg Altona Project"

Terminal Situation



Ship's hatch / Control Cabinet





Onshore Power Supply for Cruise Liner

The Requirements

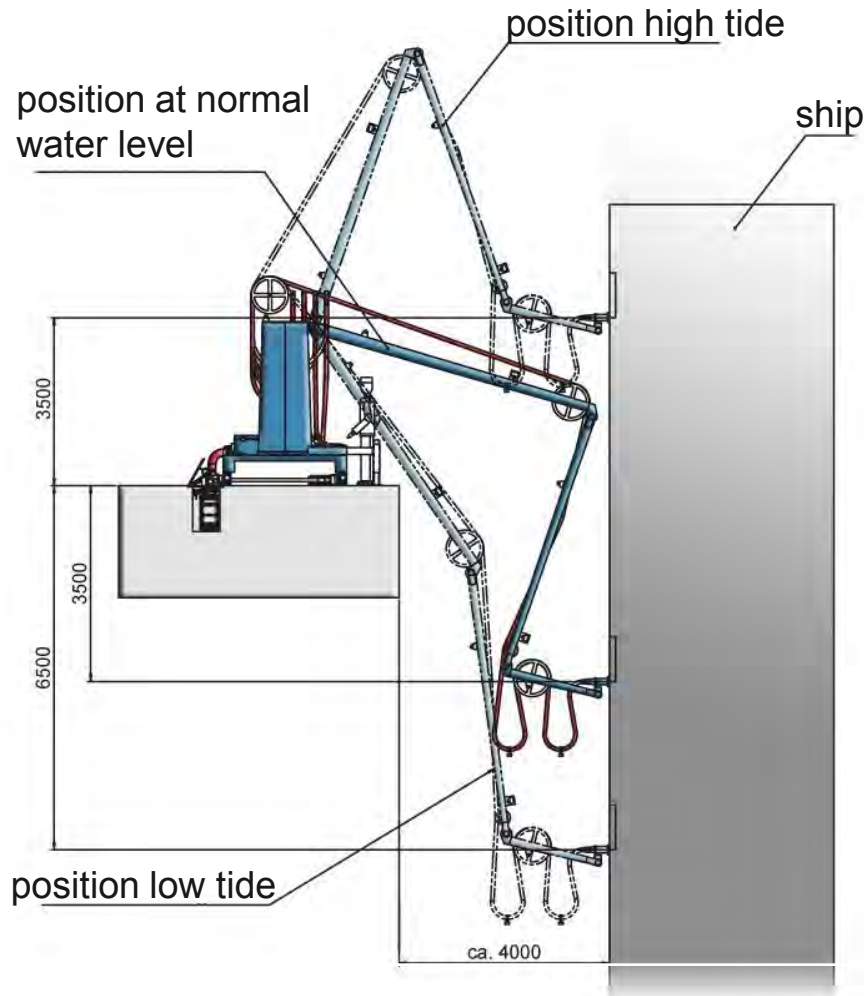

High tide, height difference hatch/quay: **3.5 m**

Low tide, height difference hatch/quay: **6.5 m**

Travel distance parallel to quay wall: **300 m**

Distance between ship and quay wall: **4 m**

Distance between SAMP-System and quay wall: **approx. 2.5 m**

Distance between hatch and socket: **approx. 3.5 m**

Hatch dimensions (h x w): **1.2 x 0.8 m**

Transmittable voltage: **12 MVA**



Onshore Power Supply for Cruise Liner

Port Side / Cable Duct / Energy Chain





Onshore Power Supply for Cruise Liner

Transfer Vehicle / Cover Lifting Device with Cable Guideway

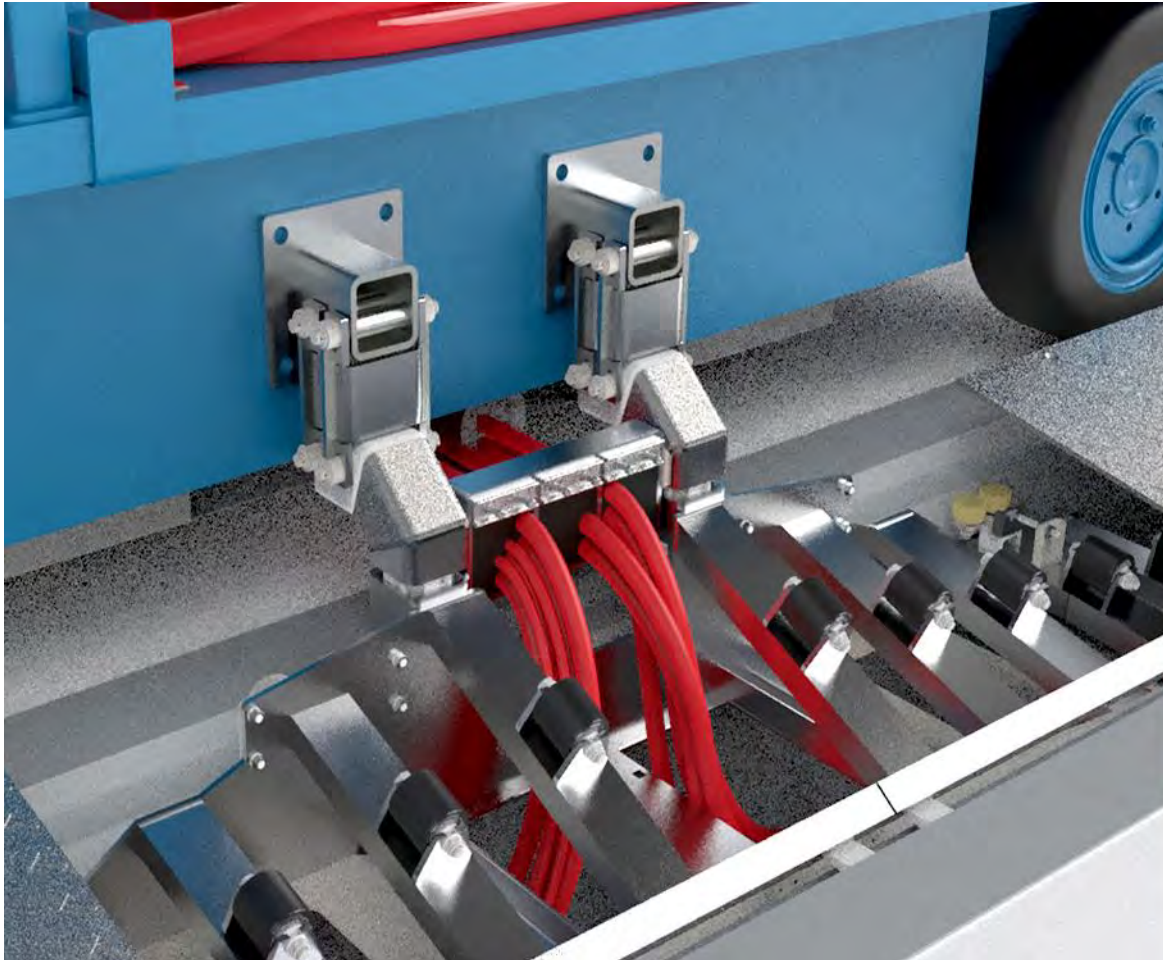

Onshore Power Supply for Cruise Liner

Telescopic Plug Holder System



Onshore Power Supply for Cruise Liner

Control Panel

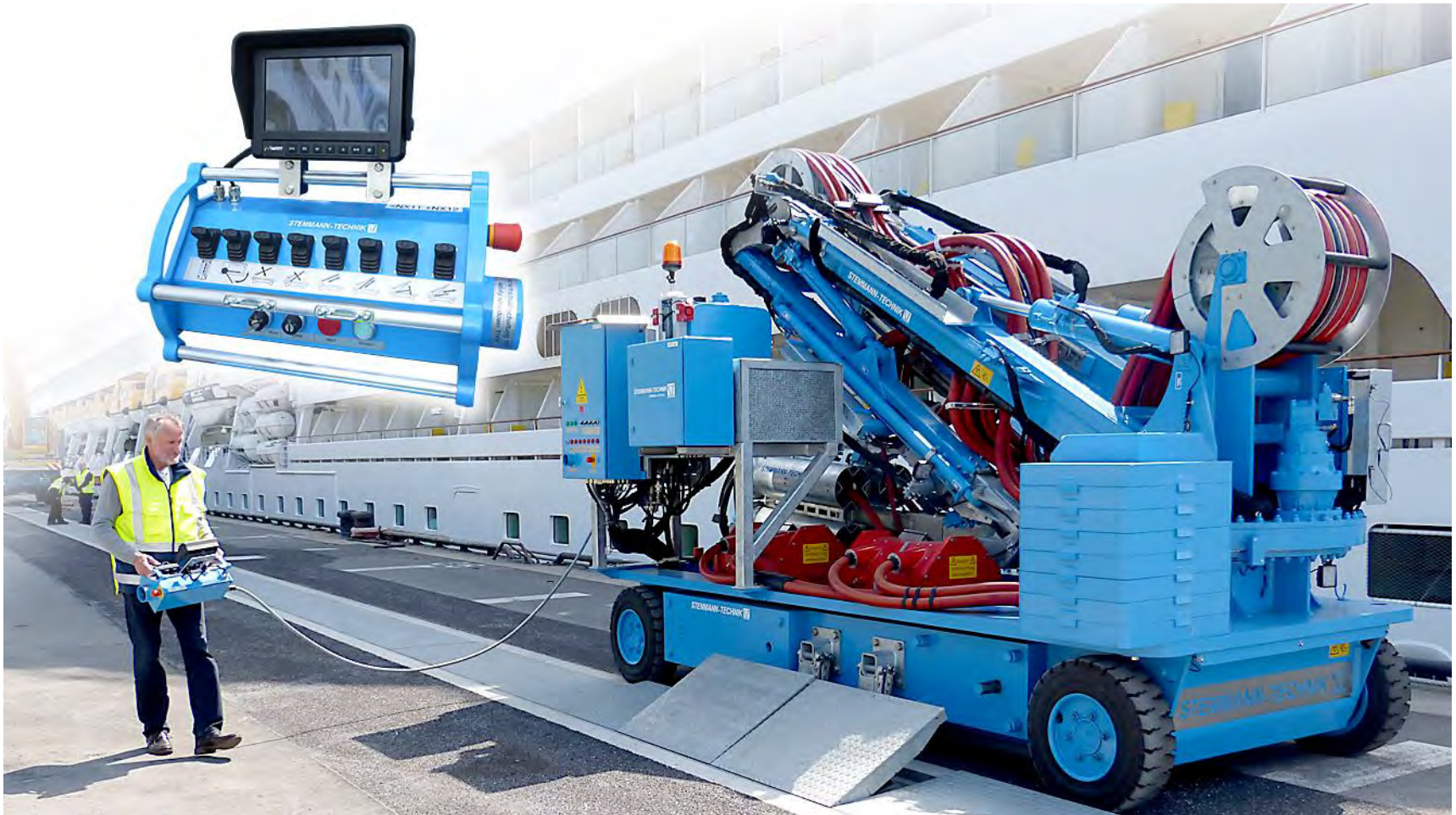



Onshore Power Supply for Cruise Liner

Story of the "SAMPS Shanghai Project"

Terminal Situation



Ship's hatch / Control Cabinet





Onshore Power Supply for Cruise Liner

Story of the "SAMPS Shanghai Project"

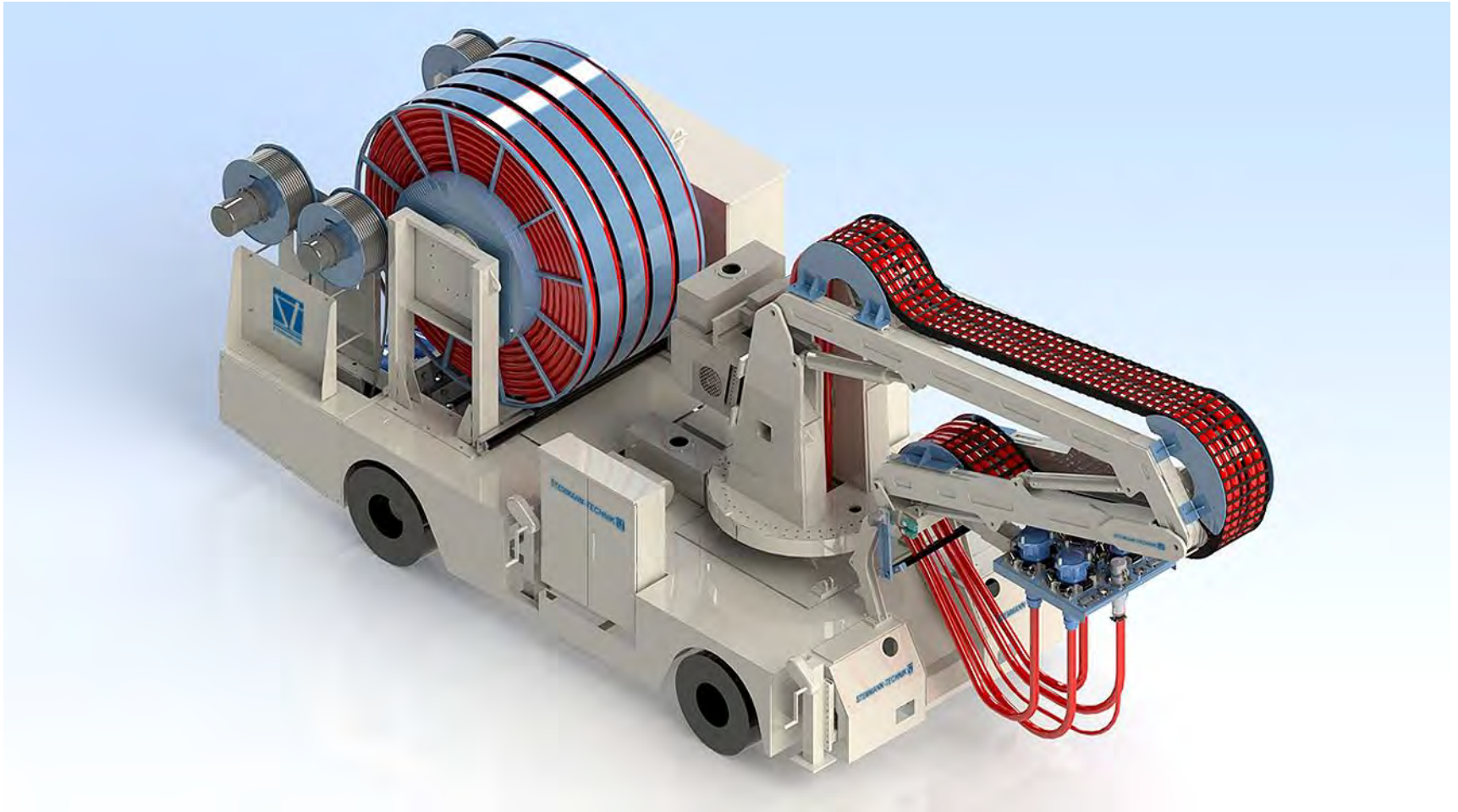



Onshore Power Supply for Cruise Liner

Story of the "SAMPS Shanghai Project"

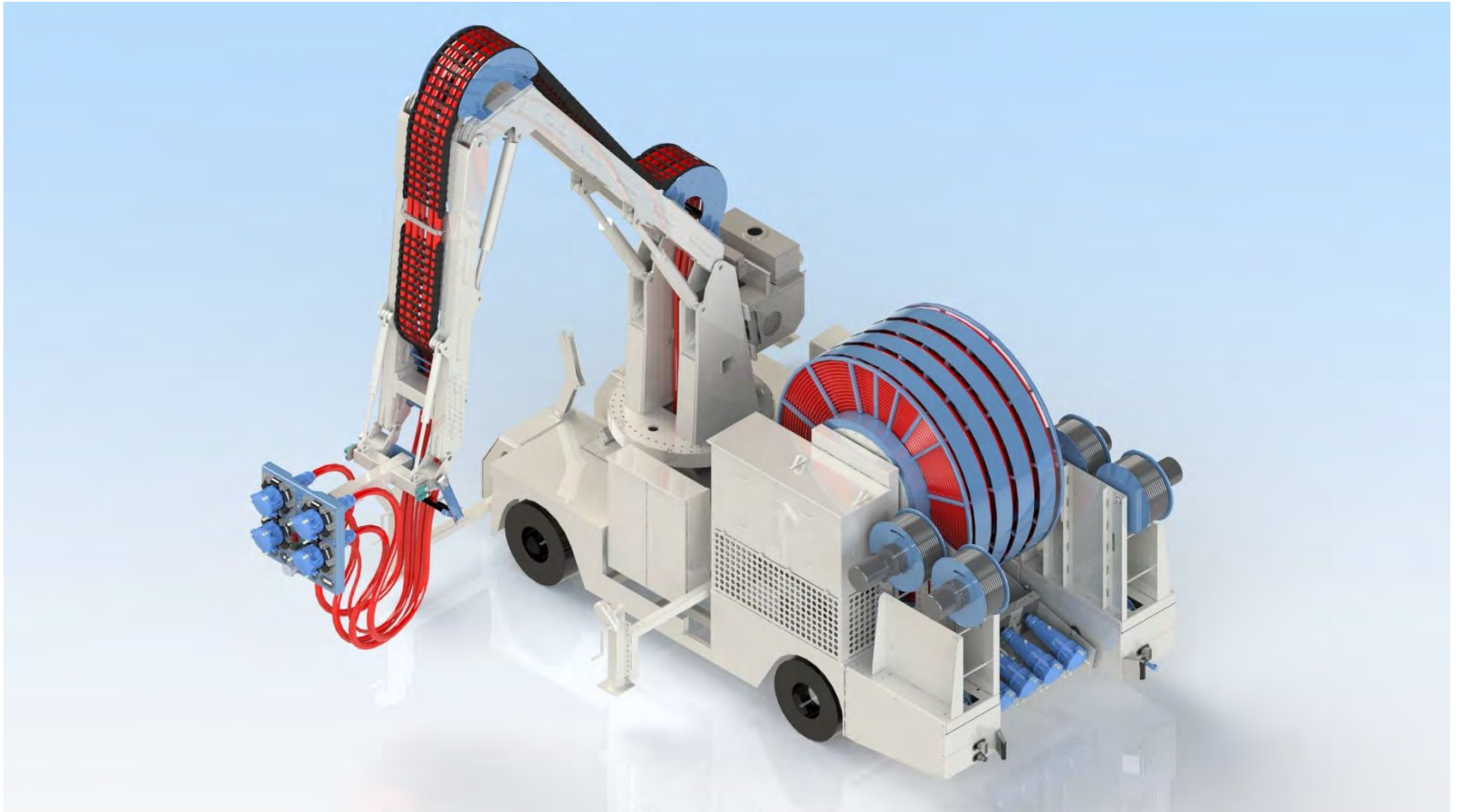



Onshore Power Supply for Cruise Liner

Story of the "SAMPS Shanghai Project"

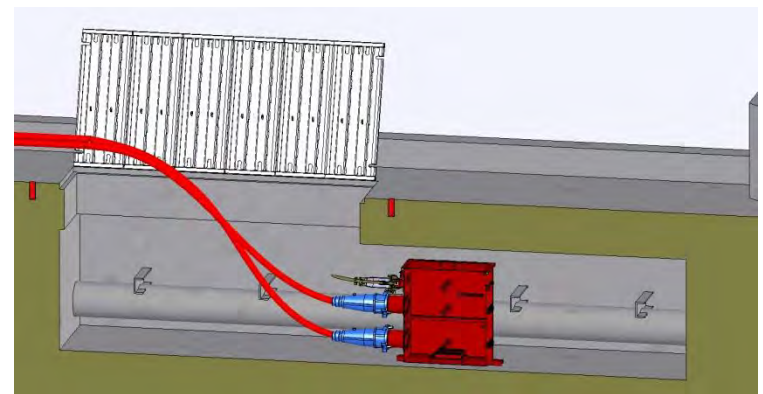
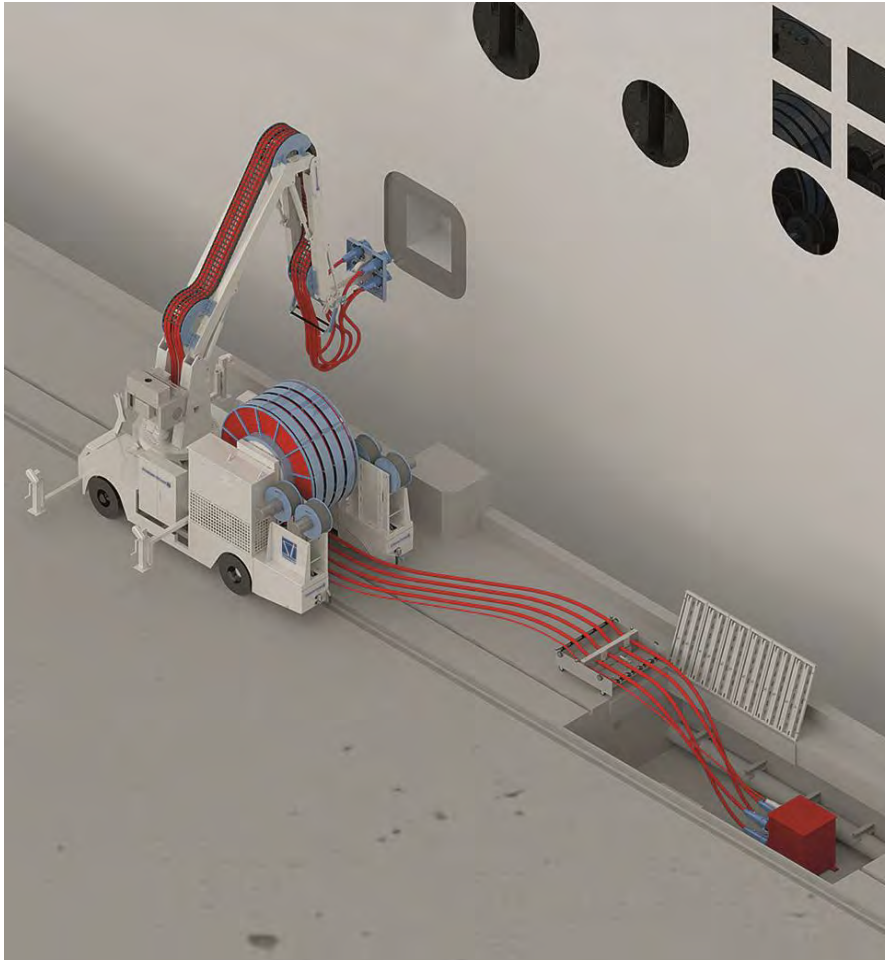



Electrical Charging System for Ferries

Quick Charging Connection via Pantograph Systems





Electrical Charging System for Ferries

Quick Charging Connection via Pantograph Systems

System especially for ferries that cover short distances

120 cars / 360 passengers

Fully recharge in 10 minutes

Passenger service since 2015

400 kW to cruise at 10 knots

Replacement of 2,000-hp diesel engine

Saving 264,000 gallons of fuel/year

Saving nearly 3,000 tons of CO₂/year

Powered by 800 kW battery





Electrical Charging System for Ferries

Pantograph System (planning phase)

low tide

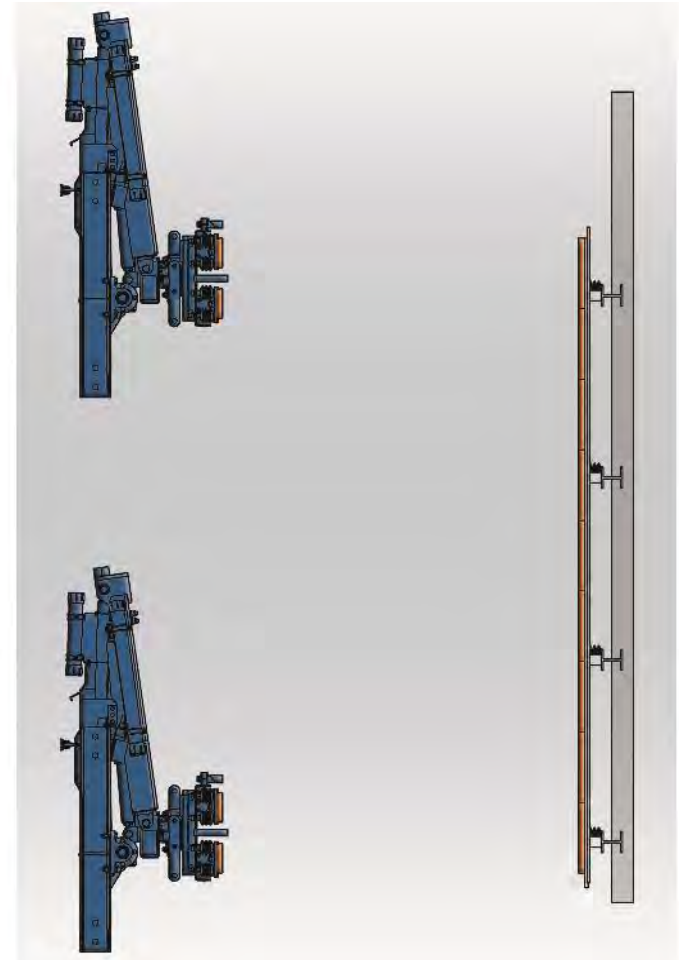
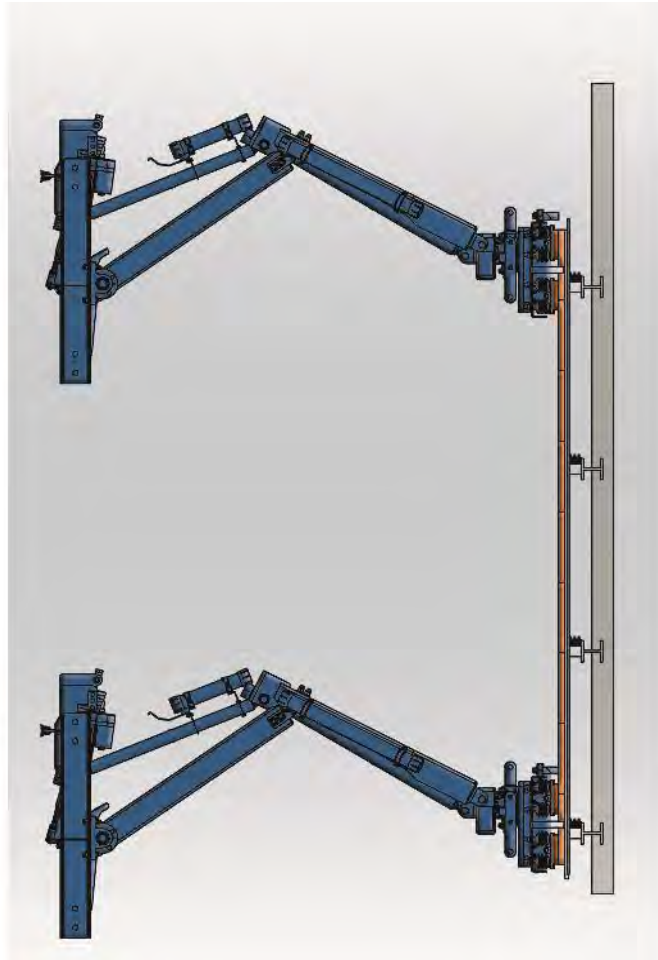

high tide



Electrical Charging System for Ferries

Quick Charging Connection via Pantograph Systems

System especially for ferries that cover short distances

Fully automated

Connecting/disconnecting
time only 7 seconds

Compensates the ferry
movement while docking

System secured into
attractive housing

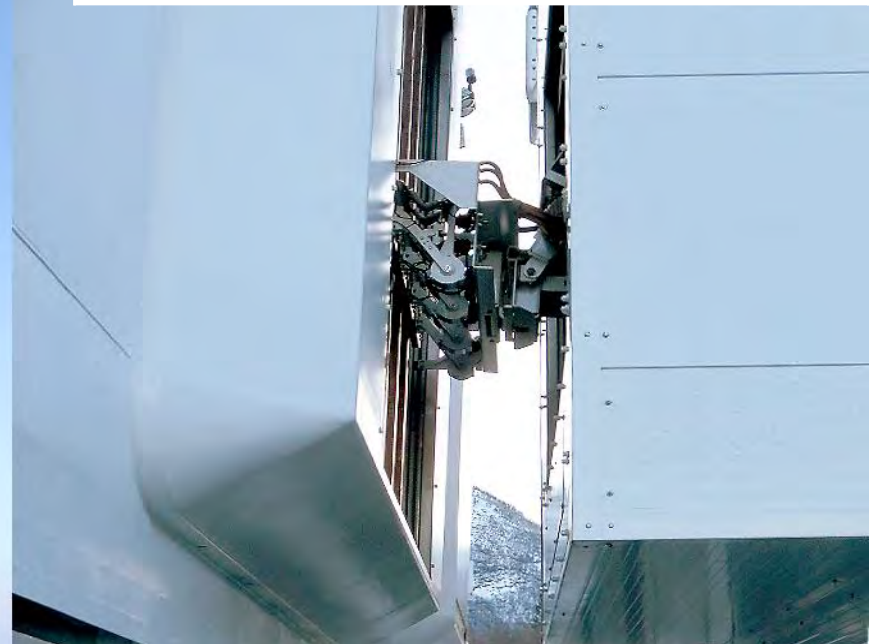

Electrical Ferry

Pantograph System (planning phase)

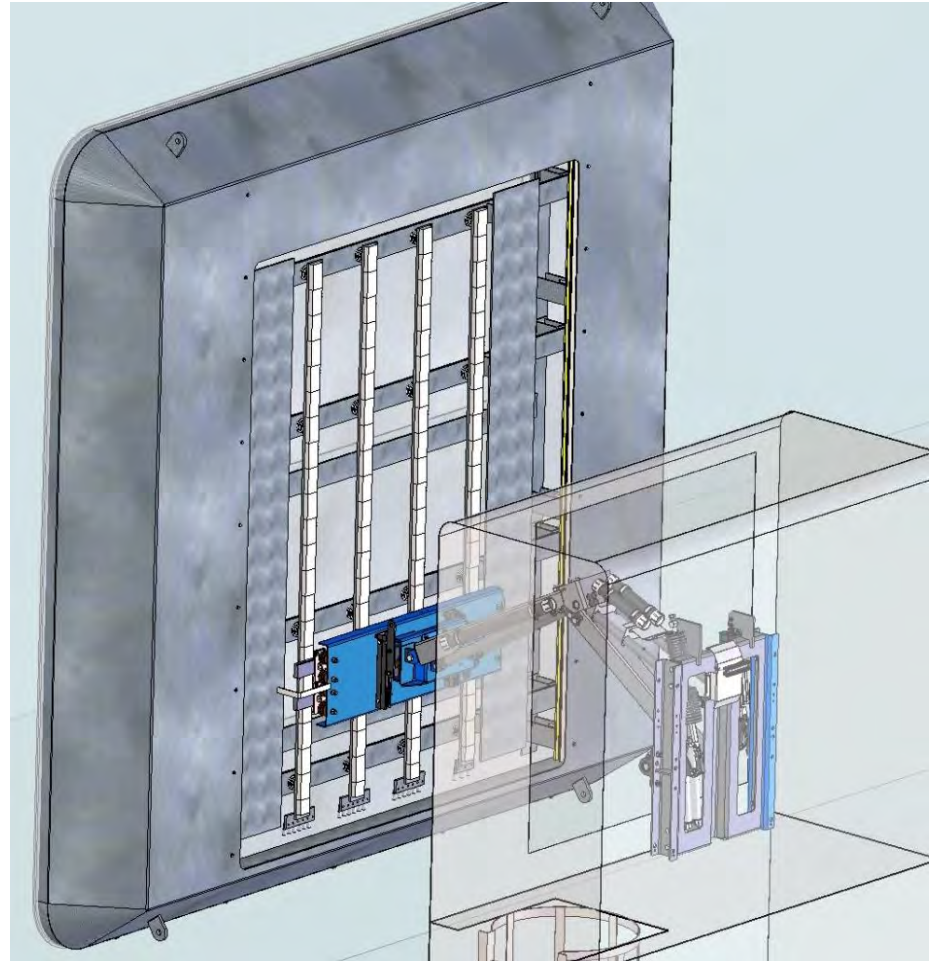
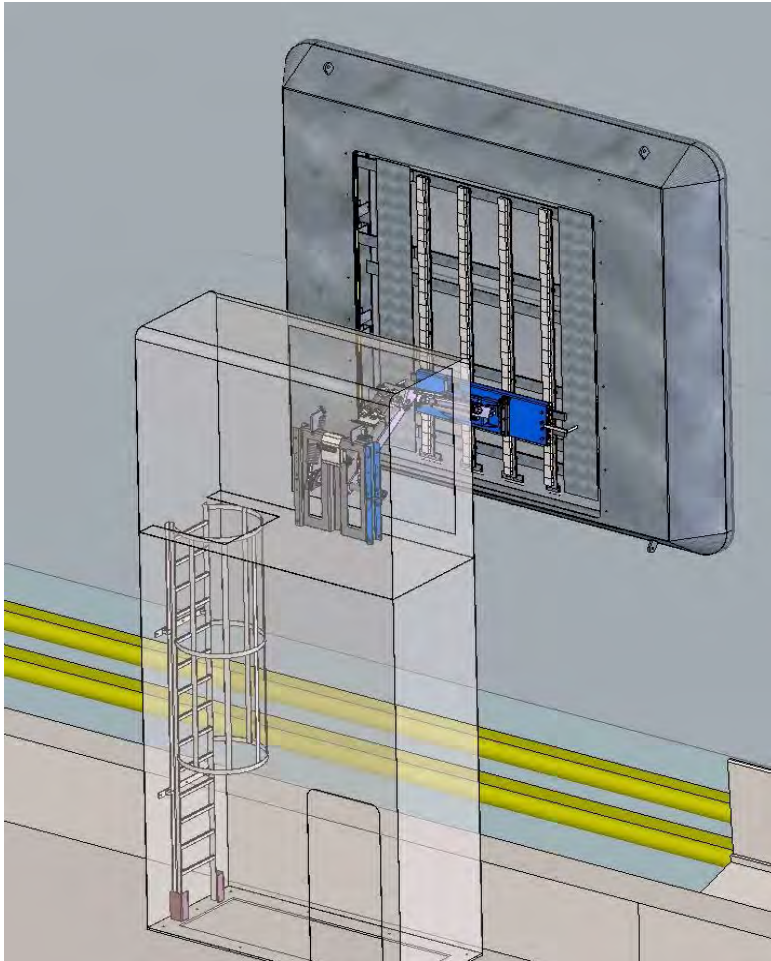

Electrical Ferry

Pantograph System (real situation)

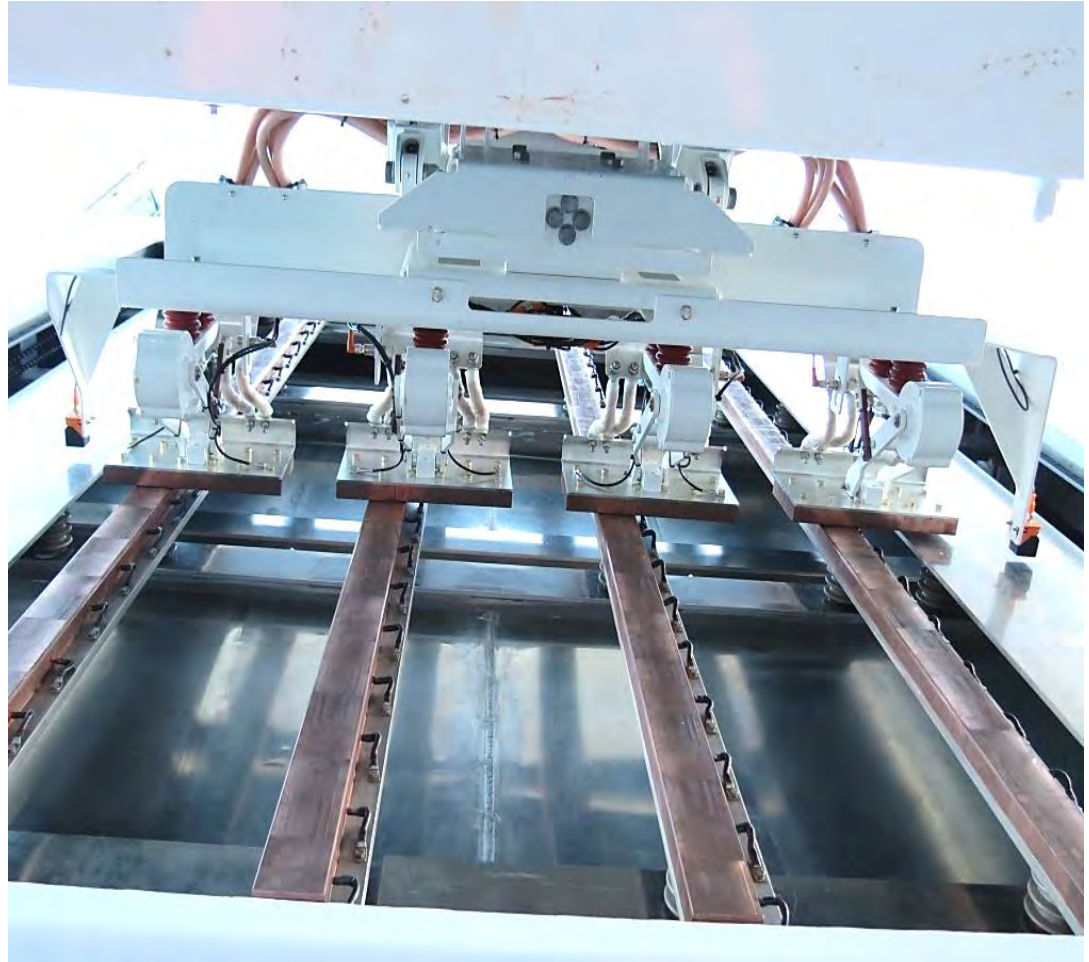



Onshore Power Supply for RoRo Vessel or Offshore Vessel



STEMMANN-TECHNIK

A Wabtec subsidiary



Thank You for Your Attention

Stemmman-Technik GmbH
Headquarter

Niedersachsenstraße 2
48465 Schüttorf | Germany

Phone: +49 5923 81 – 0
Fax: +49 5923 81 – 100

info@stemmann.de
www.stemmann.de

