

Crane Upgrades a way to extend port cranes life

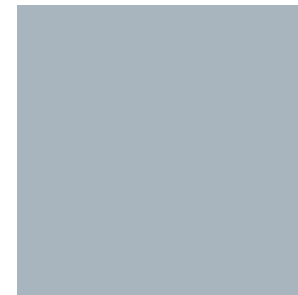

Eduardo Prat - Vice President EMEA South

12th TransMiddle East 2016
26th.-27th. October, Jeddah, Saudi



**Any Crane, Any Job,
Anywhere**

Contents

- Introduction to Kalmar
- What are Crane Upgrades
- Why to upgrade?
- Examples of crane upgrade projects
- Conclusions

Kalmar – Making your every move count.



- Kalmar is part of Cargotec
- Cargotec is listed on the stock exchange with sales totaling EUR 3.729 million in 2015 and employs approximately 11.000 people.
- Approximately 5.300 people are employed in Kalmar Service Centers in more than 100 countries world wide
- Kalmar is market leader in container handling equipment, port automation and services with sales in 2015 of EUR 1.678 million

One in four container movements around the globe is handled by a Kalmar solution.



Kalmar provides the market's widest product portfolio

Automation & Projects Division

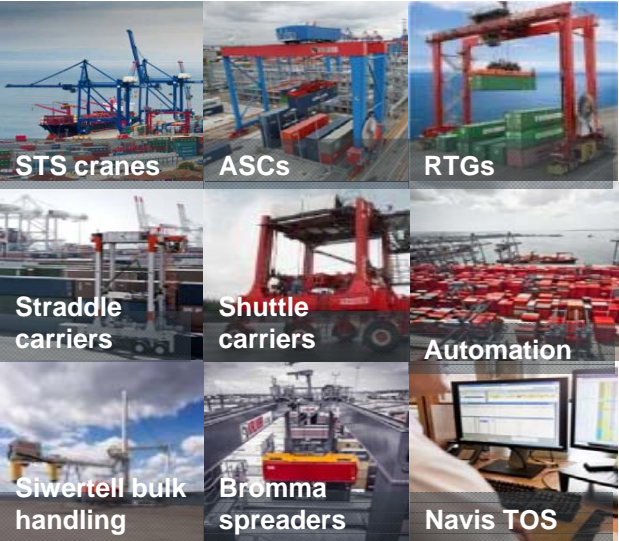

Mobile Equipment Division



Services Division

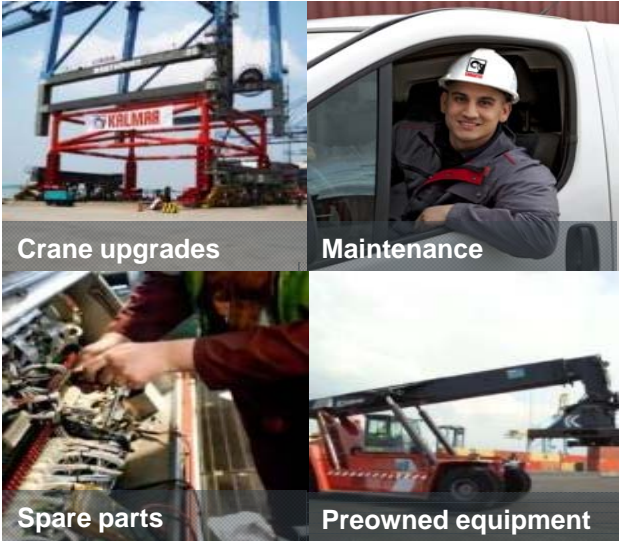



Kalmar OneTerminal - the first integrated solution for automated terminals

Crane Upgrades is part of Kalmar Services

EQUIPMENT

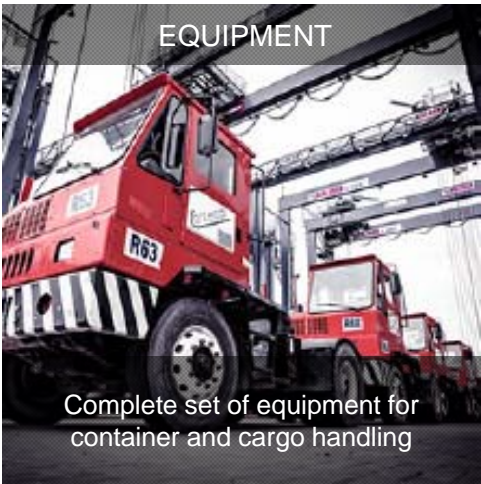

Complete set of equipment for container and cargo handling

SERVICES



Global service network
Upgrades and refurbishment
Service contracting
Terminal development

SYSTEMS & AUTOMATION



Terminal operating systems
Automated equipment
Process automation

MAINTENANCE



CRANE UPGRADES



PREOWNED EQUIPMENT



SPARE PARTS



What are crane upgrades?

- Crane Upgrades are sizeable projects that enhance the use existing of cranes
- They are performed on large cranes capable of lifting containers or other heavy loads in yards or ship loading/unloading operations
- Typical products include STS cranes, RTG cranes, ASC cranes and straddle carriers
- Upgrades aim to improve either crane productivity, safety, physical dimensioning or physical operating location
- Our projects are based on over 80 years of experience and our key resources include engineering, project management and/or site management

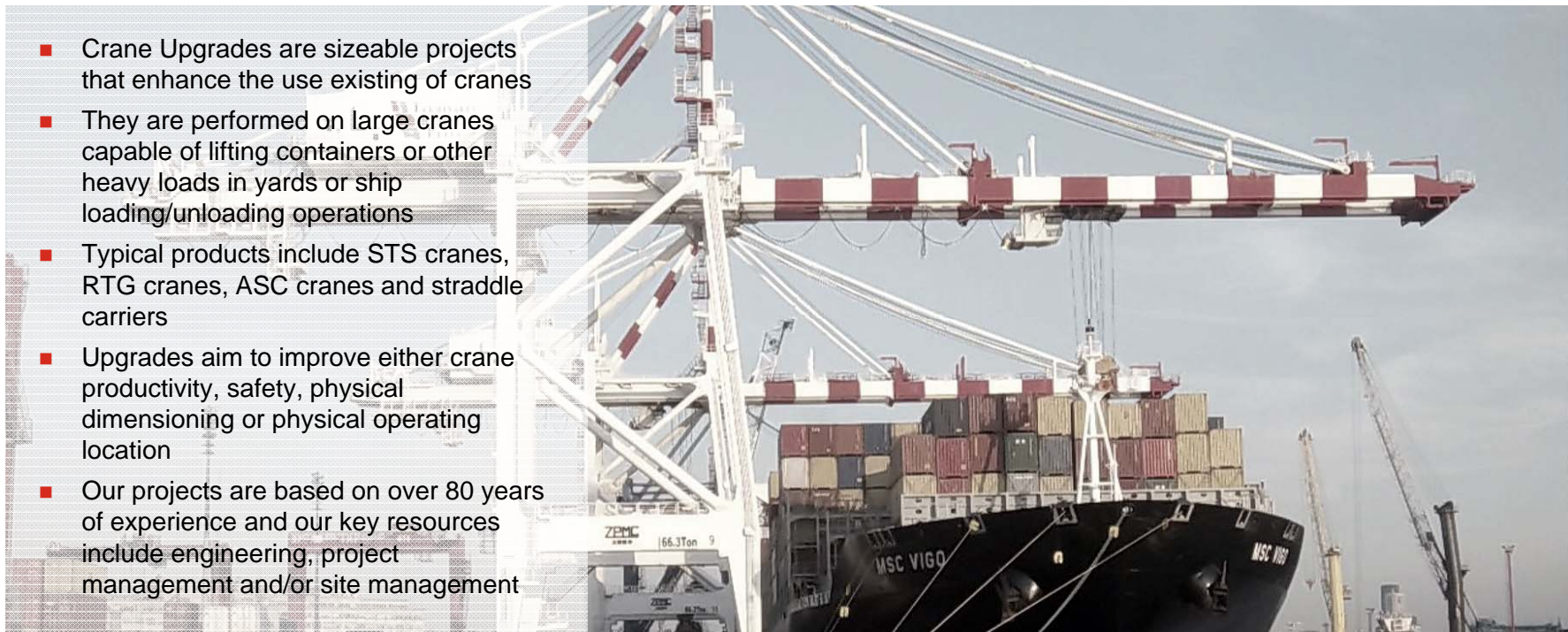

Why upgrade?

Increasing container volumes	Challenge: increasing wear and tear for cranes Solution: inspections, repair and refurbishment
Increasing terminal competition	Challenge: increasing demands on crane performance Solution: consultancy and inspections, upgrades, modernisation and relocation
Increasing vessel sizes	Challenge: technically competitive cranes become physically too small Solution: consultancy and inspections, upgrades
Increasing need for sustainability	Challenge: being receptive to green values, with acceptable ROI Solution: upgrades and modernisation

Examples of crane upgrades projects

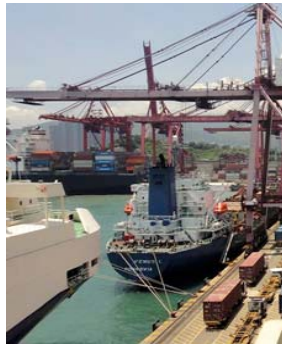

Hong Kong
Structural visual inspection of four non-Kalmar STS cranes



Port Klang, Malaysia
Refurbishment of 14 non-Kalmar straddle carriers



Yilport, Turkey
Electrification of 18 non-Kalmar RTGs

- Installation and commissioning of pneumatic actuated automatic drive-in units
- Conductor bar system



Marseille, France
Upgrade of three non-Kalmar STS cranes

- Gantry upgrade
- SPMT relocation
- Electrical modifications



Rotterdam, the Netherlands
Upgrade of 12 non-Kalmar STS cranes

- 8-metre height increase
- 4-metre boom extension
- Stacker platform
- Lifetime extension

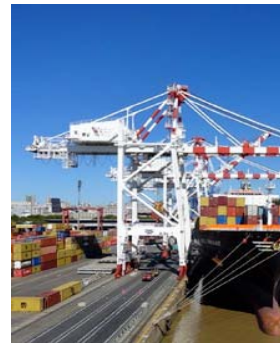

Buenos Aires, Argentina
Boom extension and relocation of two non-Kalmar STS cranes

- 6-metre boom extension

Any Crane / Any Job / Anywhere



Examples of crane upgrades projects



TCB Barcelona – 2014/15
 Heightening 6 meters 3 ZPMC STS Cranes

- Total Control of the Project
- Execution the whole works on site - Safety is our priority



Port Said PSCCH – Egypt – 15
 Boom Repair on a Noell STS Crane

- Complete Engineering Works
- Provide right Technical Solution
- Execution and Control of the Works
- Testing Protocol

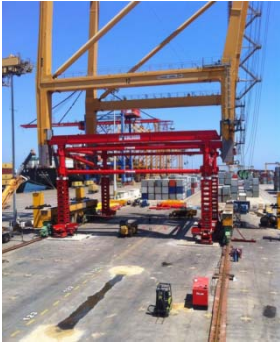

Paceco Valencia15
 Heightening 7 meters 2 Paceco STS Cranes

- Subcontractor of OEM (Paceco)
- Skidding the cranes and execution the whole works on site - Safety is our priority

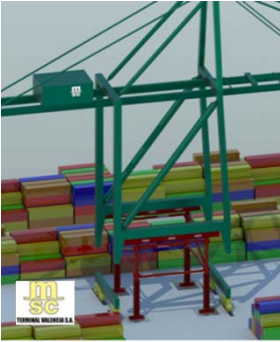

MSCTV Valencia – In execution
 6 STS Crane Heightening and 8 STS Boom extension Works

- Manufacturing Control
- Relocate the cranes: Skidding and SPMT
- Crane Heightening and Boom Extension Works
- Testing Protocol
- Certification of the Cranes



Port Said SCCT – In execution
 Securing crane after vessel collision

- Complete Engineering Works: Survey and securing proposal
- Provide right Technical Solution
- Manufacturing Control
- Execution and Control of the Works



Abidjan – Ivory Coast15
 Repair Kalmar STS Crane after accident

- Complete Engineering Works: Survey and repair proposal
- Provide right Technical Solution
- Manufacturing Control
- Execution and Control of the Works
- Testing Protocol

Any Crane / Any Job / Anywhere



Heightening and boom extension, MSCTV Valencia

Heightening with 10 meters of 6 STS cranes and 6 meter boom extension of 8 STS cranes

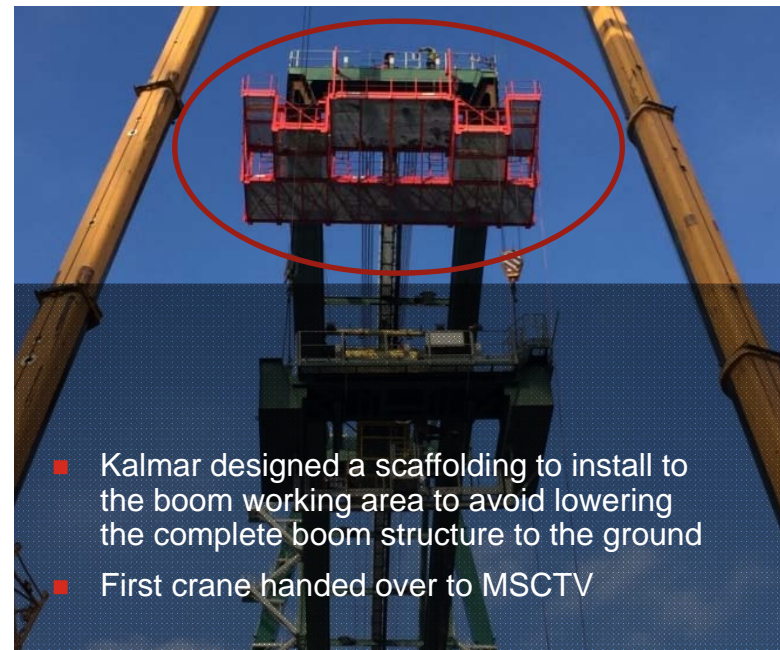

Any Crane / Any Job / Anywhere



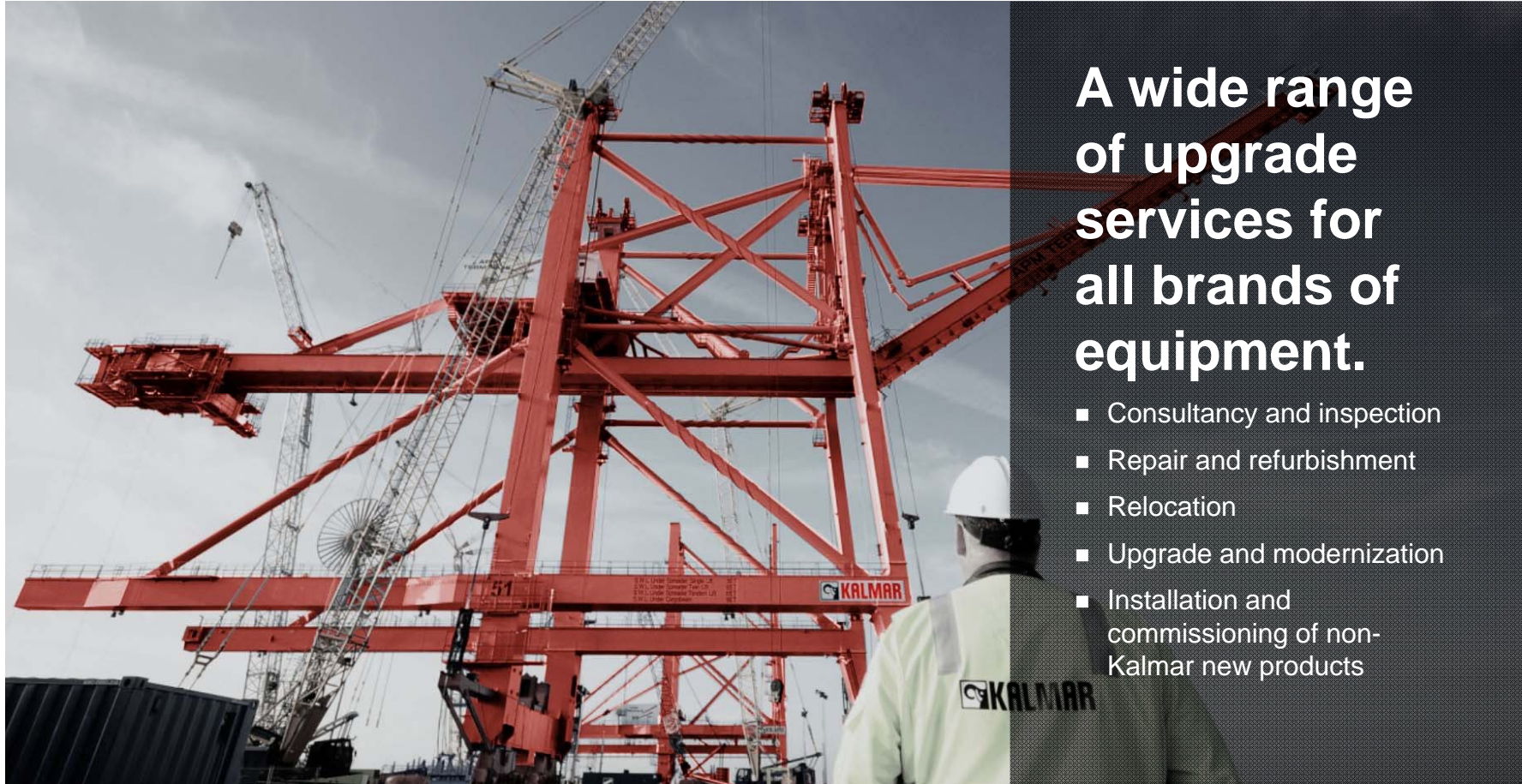

A wide range of upgrade services for all brands of equipment.

- Consultancy and inspection
- Repair and refurbishment
- Relocation
- Upgrade and modernization
- Installation and commissioning of non-Kalmar new products

Any Crane / Any Job / Anywhere



Consultancy and inspection

- Damage survey
- Equipment modification study
- Lifetime analysis and inspection
- Lifetime extension plans
- Planning for crane upgrade project

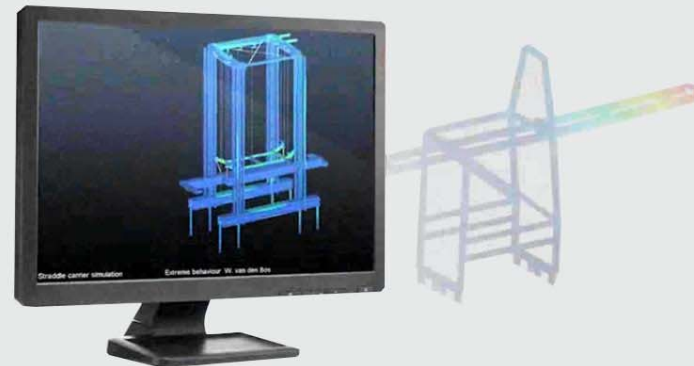

Any Crane / **Any Job** / Anywhere



Repair and refurbishment



Festoon installation

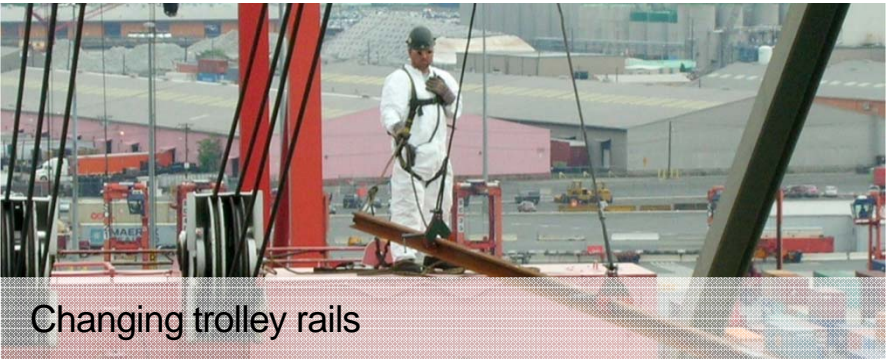

Changing trolley rails



Crane control system and/or motors



Replacing cable reel

Any Crane / Any Job / Anywhere



Relocation



- Moving cranes to another location by land, river or sea
- An increasingly popular choice as terminals adapt to quickly changing needs and seek to optimise their investments

Any Crane / Any Job / Anywhere



Relocation – within a terminal

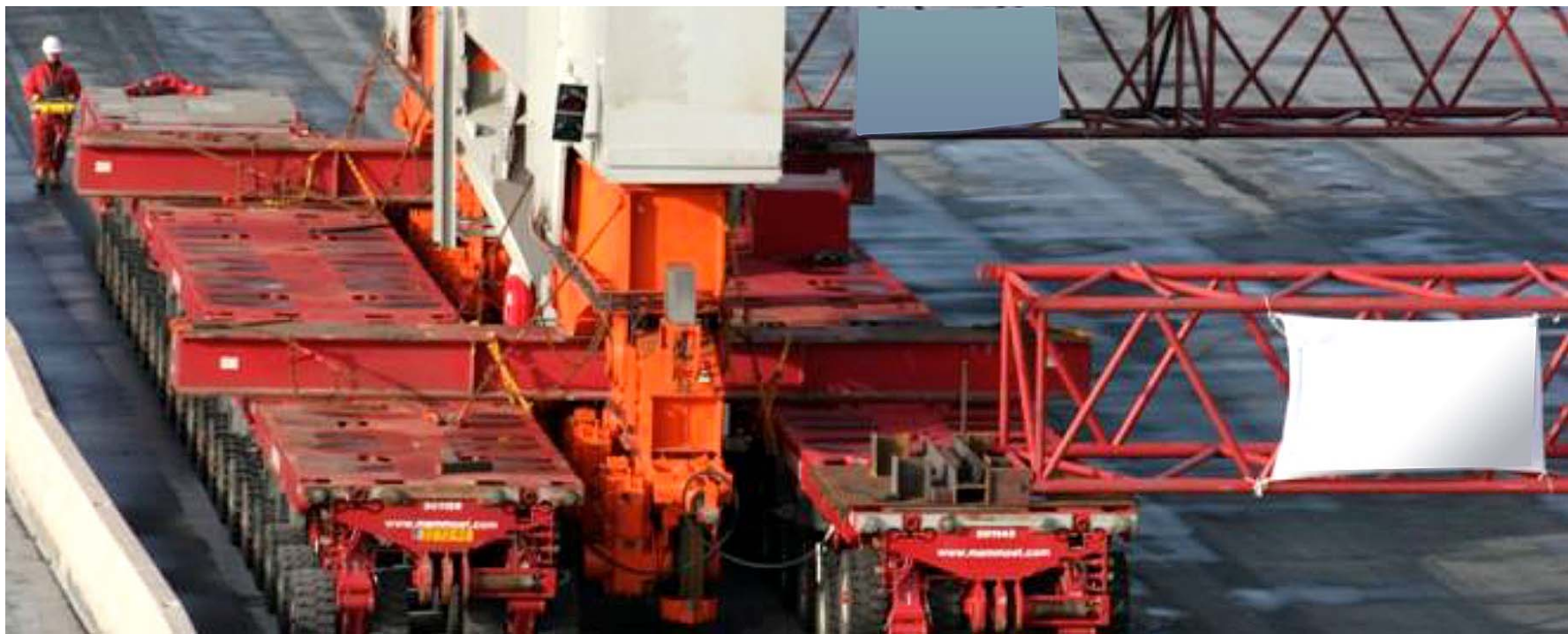

Any Crane / Any Job / Anywhere



Relocation – transport by sea



Sea transport
relocation of STS
crane with rail gauge
modification for new
terminal

Any Crane / Any Job / Anywhere



Upgrade and modernisation

- Crane heightening and boom extension
- Modernisation of main components (control system, electric motors and cabin etc.)
- Safety additions (stacker platform, boom anti-collision and cameras etc.)
- Environmental and energy saving options (electrification of RTGs and fuel saving engine controllers etc.)
- Automation and operator assisting features (spreader soft landing etc.)



Any Crane / Any Job / Anywhere



Upgrade and modernisation – growing ship sizes and volumes are met in most terminals

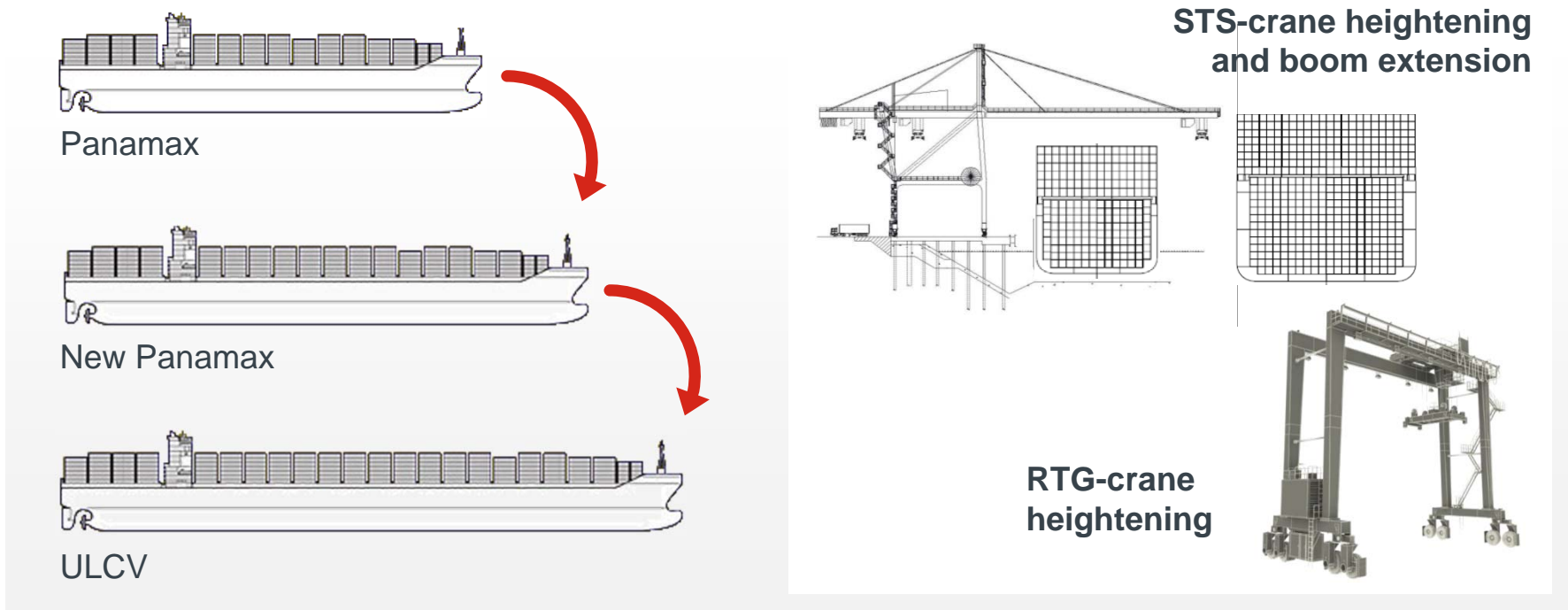

Any Crane / Any Job / Anywhere



Upgrade and modernisation – STS-crane heightening and boom extension

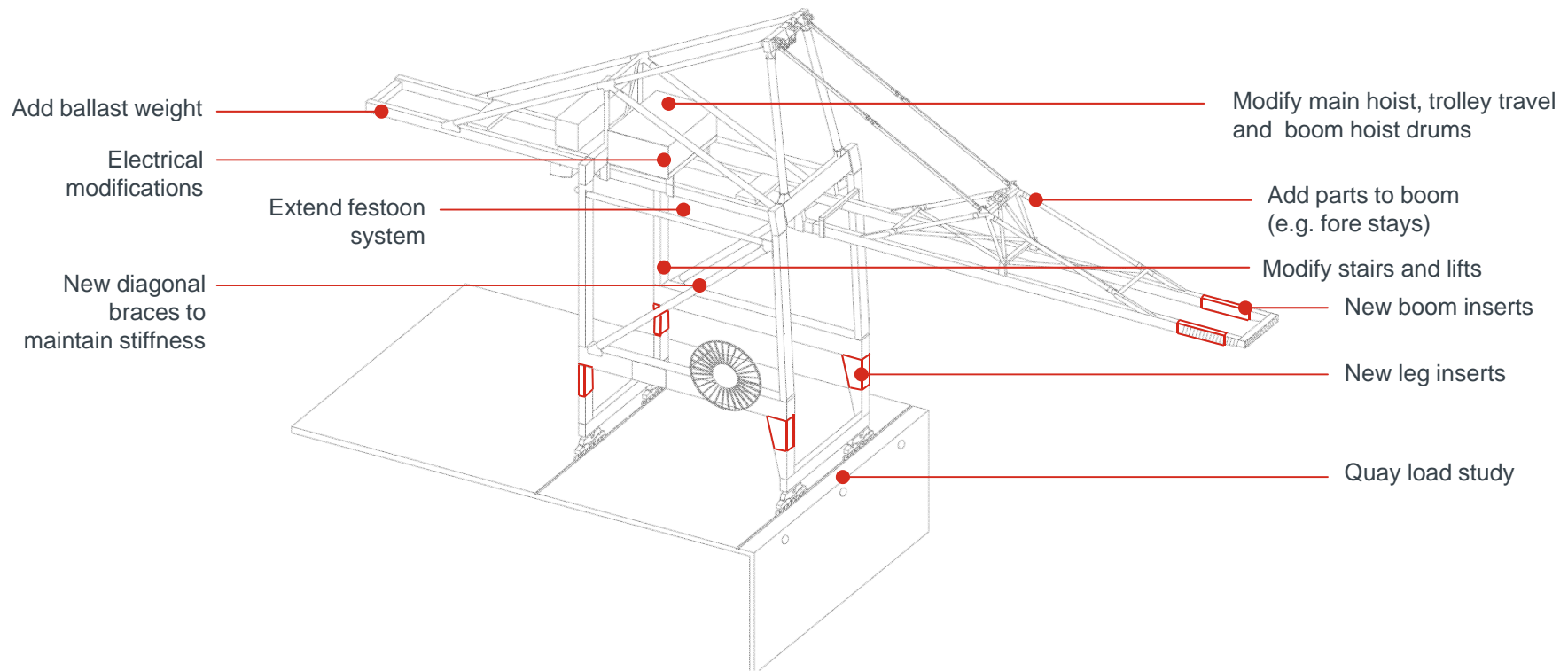

Any Crane / Any Job / Anywhere



Upgrade and modernisation – RTG-crane heightening

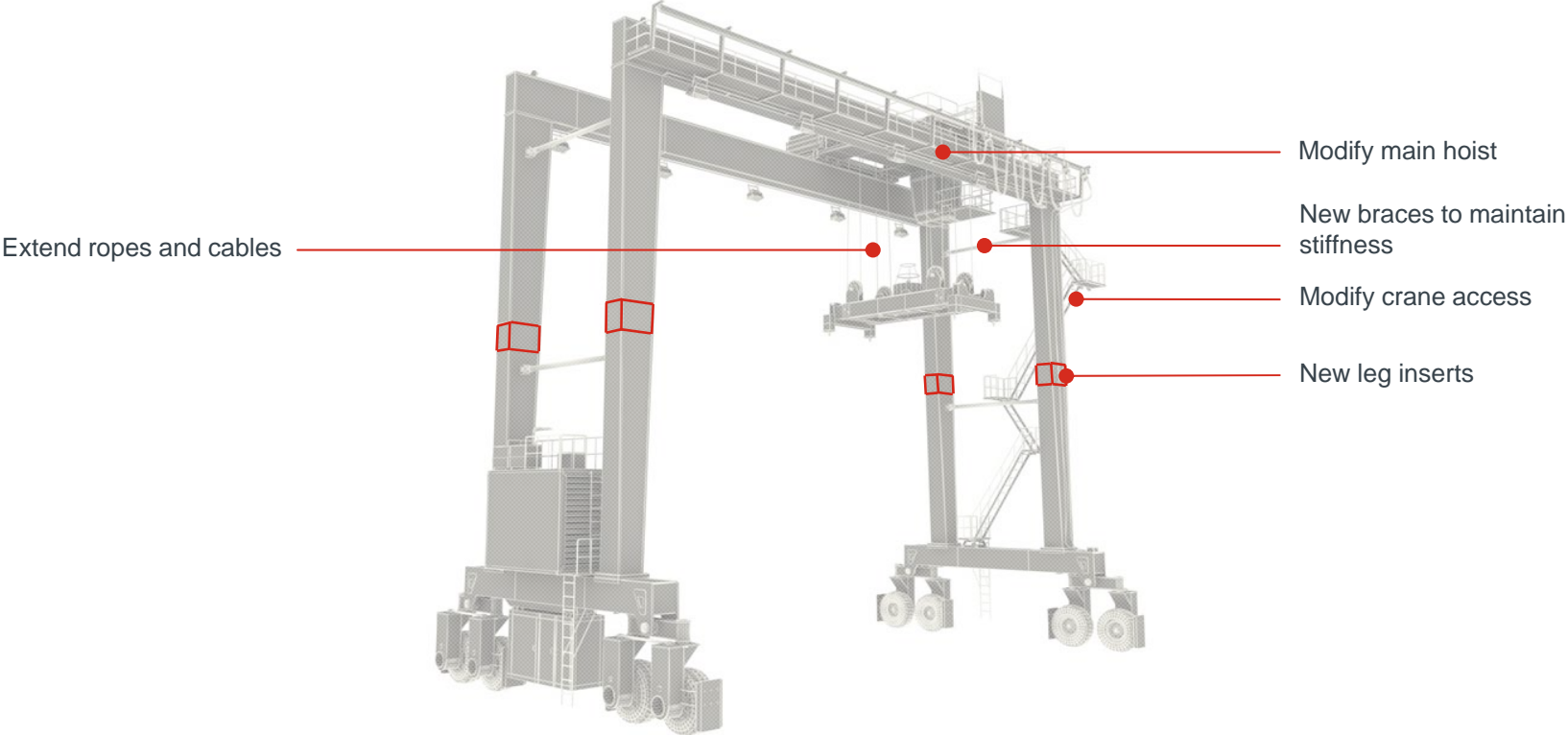

Any Crane / Any Job / Anywhere



Upgrade and modernisation – budget and time indications

Budget indication (K€/ crane)

STS boom extension	250 – 1,000
STS crane heightening	750 – 1,250
RTG heightening	75 – 200

Time from order to delivery (months)

STS boom extension	6 – 12
STS crane heightening	6 – 12
RTG heightening	2 – 4

Crane out of operation (weeks)

STS boom extension	6 – 10
STS crane heightening	6 – 10
RTG heightening	2 – 4

Any Crane / Any Job / Anywhere



Upgrade and modernisation – two basic ways to electrify RTG cranes



Saving of about
35,000 litres of diesel
fuel per year / crane

Zero emissions,
no engine noise

Less maintenance –
increased availability

Any Crane / Any Job / Anywhere

 **KALMAR**

Upgrade and modernisation – a rapid return on investment

Savings

Diesel Electric RTG (3,000 hours per year)	Electrified RTG (3,000 hours per year)
18.0 litres/hour	40 kW/hour
1.25 €/litre	0.05 €/kWh
54,000 litre/year	120,000 kWh/year
67,500 €/year	6,000 €/year
Approximate savings per RTG per year: €60,000 = US\$ 75,000	

ROI expectation: 2 - 4 years (depending on the scope and fuel price)

Variables: Total container block length; conductor bar structure or cable length / Local price level for labor and hardware structures / Single or double sided connection (conductor bar) / Filtering of electric power / RTG voltage transformation / various other minor technical challenges.

Any Crane / Any Job / Anywhere



Any job



Any Crane / **Any Job** / Anywhere



Five regional business centres that cover the world



Any Crane / Any Job / Anywhere



Summary

Why upgrade?

- Maximise the use of your current assets
- Handle bigger vessels and larger volumes
- Optimise crane performance
- Meet your sustainability targets
- Improve safety

Why choose Kalmar?

- A trusted partner with a solid track record and service mindset
- Global reach
- Any crane, any job, anywhere.



Video Crane services projects

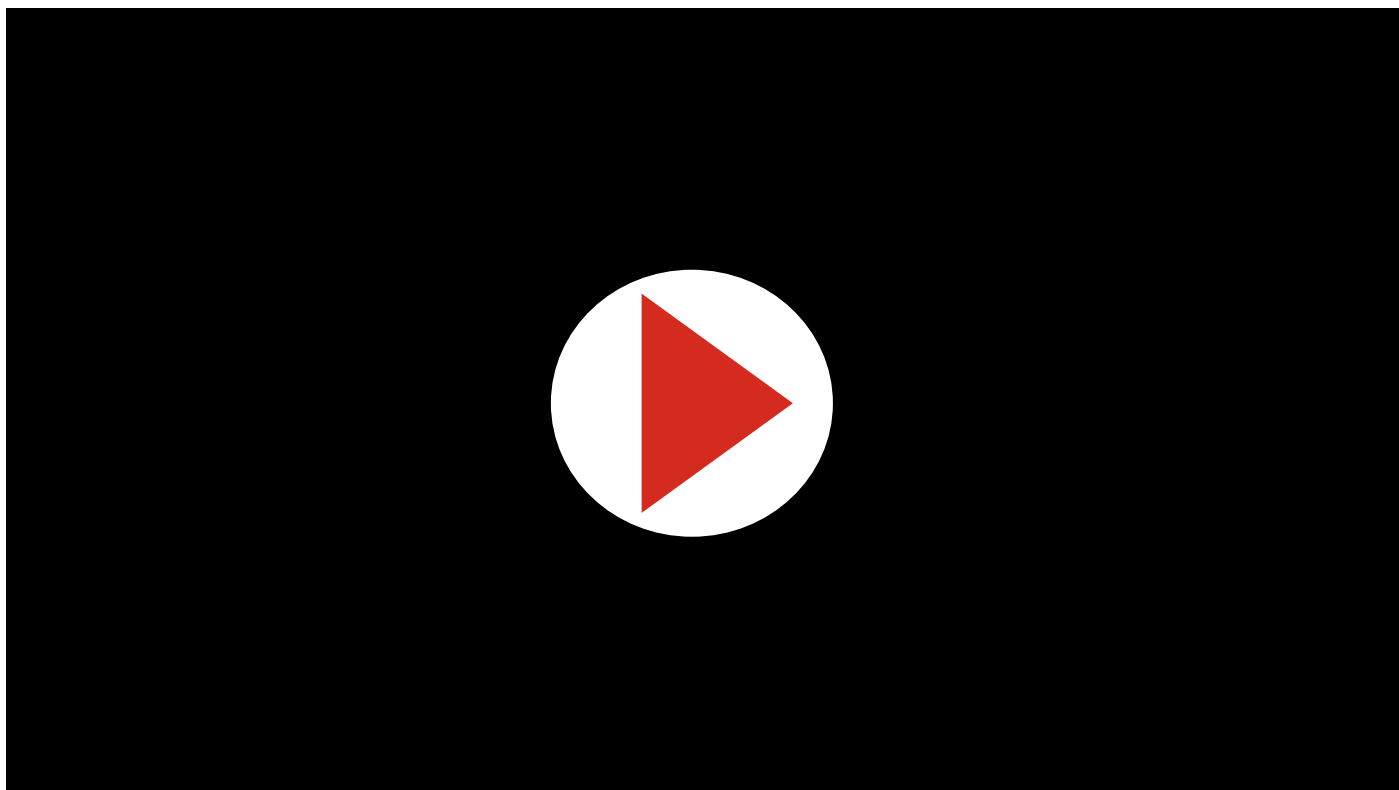



Thank you!

eduardo.prat@kalmarglobal.com
www.kalmarglobal.com