

SIBRE

Siegerland Bremsen GmbH

THE WORLD OF ADVANCED BRAKE TECHNOLOGY

*Increasing Operational Efficiency and Equipment Health Through Brake Technology
and Monitoring*

Pramit Gangopadhyay
Technical Sales Engineer



Global Sea Freight Market - 2023



US\$ 9.5 Billion
market



4.3% year on year
growth rate



22.2 million TEU
handled by top 10
shipping operators



90% of global supply
chain.



70% through
containerized cargo.

Pertinent Objectives



Continuity of supply chain.



Safe and smooth container handling operations.



Reduced downtime



Increased lifetime of operating equipment.

SIBRE Germany – About Us

- Private owned
- Founded in 1958
- Headquarter in Haiger
- Assembly plant in ESCHENBURG
- Total production area 17.500 m²





- Almost 300 employees
- 13 SIBRE subsidiaries
- More than 50 partners / agents



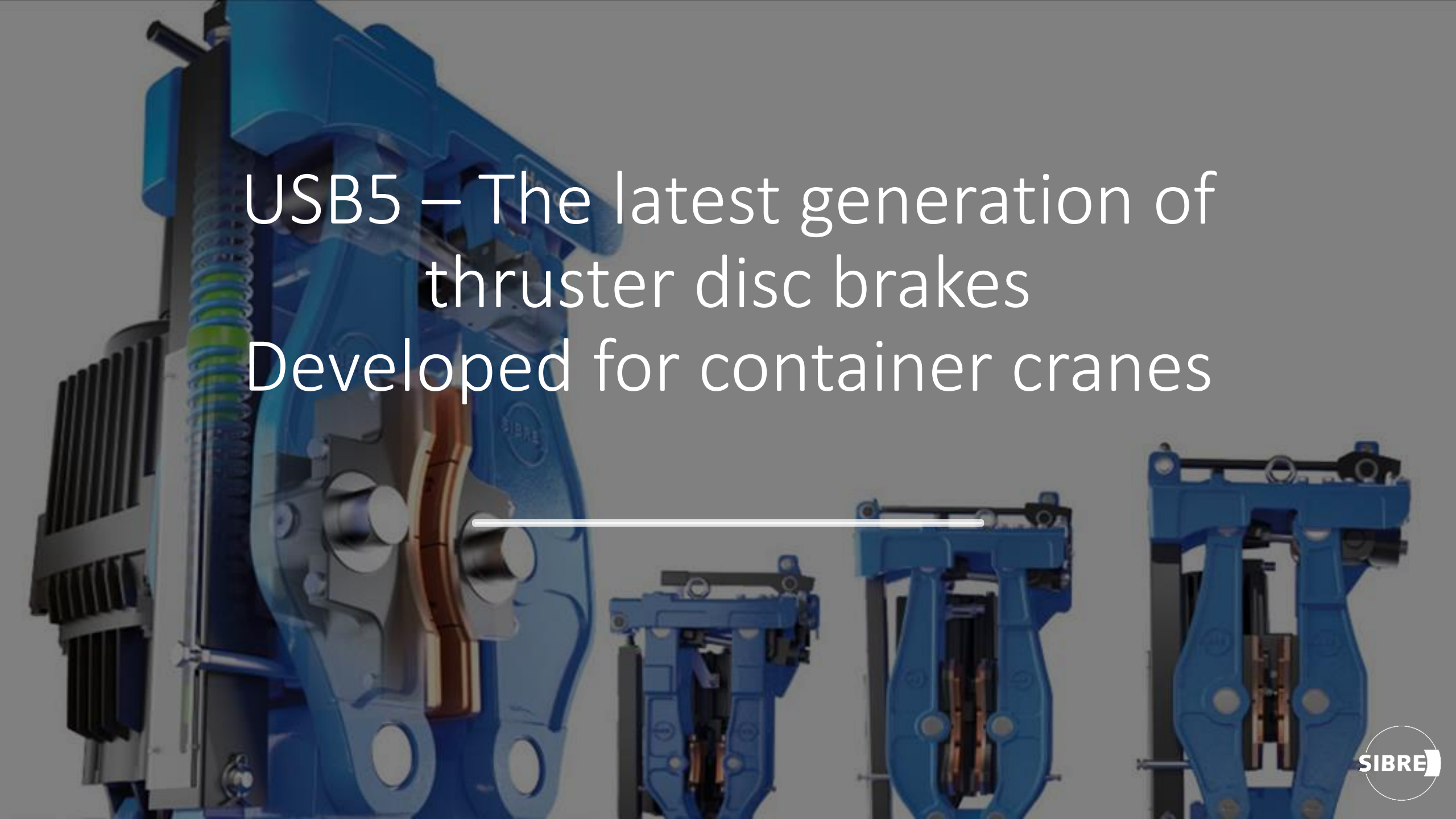

USB5 – The latest generation of
thruster disc brakes
Developed for container cranes

Improved Features – USB5

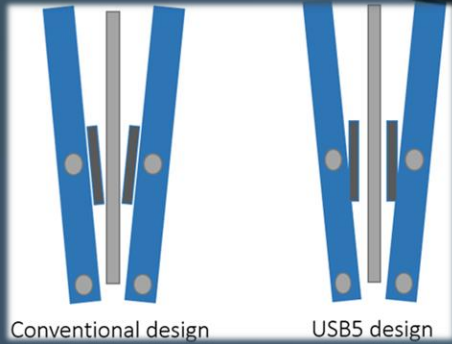

Parallel opening of brake shoes

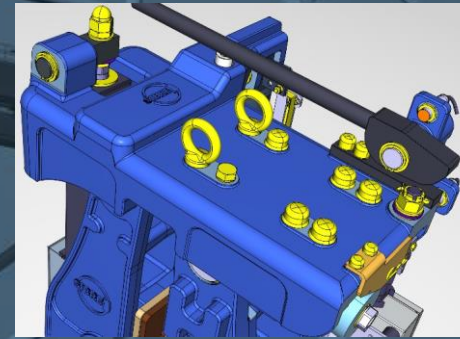

Enhanced corrosion protection



Optimized spring unit.



Upgraded manual release system

USB5 - Designed for all applications in a crane

Identical conditions in regards to installation, adjustment and maintenance

boom hoist
USB5-II or USB5-III

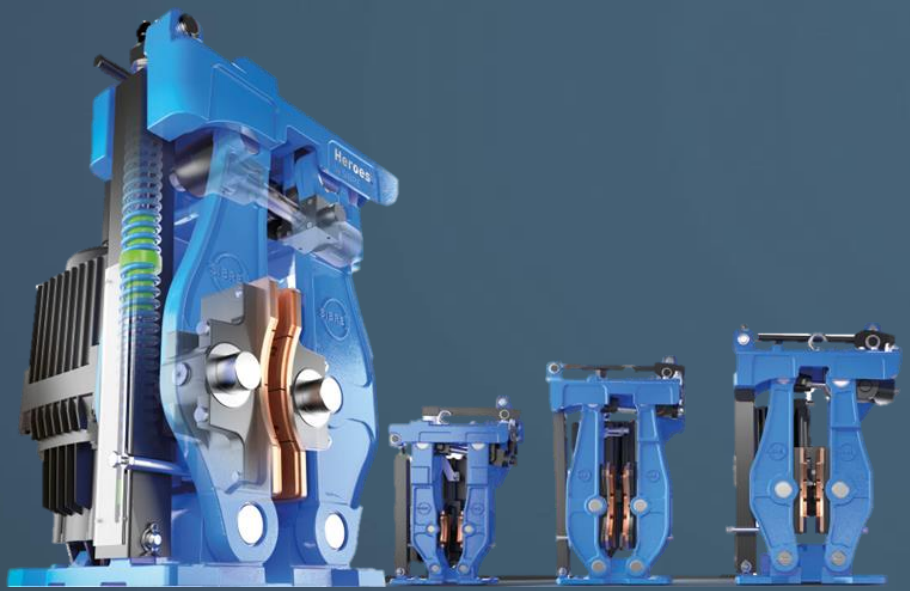

main hoist
USB5-V



trolley travelling
USB5-I or USB5-II

gantry travelling
USB5-05



Standardized functional principle, available in different sizes



USB5-05

brake torque:
100 - 690 Nm

centre height:
160 mm

weight:
46 kg



USB5-I

brake torque:
550 – 5.500 Nm

centre height:
230 mm

weight:
85 kg



USB5-II

brake torque:
1.300 - 9.800 Nm

centre height:
280 mm

weight:
175 kg



USB5-III

brake torque:
3.500 - 26.000 Nm

centre height:
370 mm

weight:
250 kg



USB5-V

Brake torque:
6.000 - 29.000 Nm

centre height:
280 mm

weight:
285 kg

Equipment Monitoring and Control

SIBRE Status Monitoring (SSM)



Crane Monitoring

- Brake status Monitoring
- Trouble Shooting
- Operational Manual and check List
- Tutorial Video

Remote Monitoring

- From maintenance Room
- Preventive Actions through warnings and Alarms
- Reduced unplanned downtime
- Optimization of the maintenance Team.

Remote Service

- Data Storage to Cloud
- Remote Helpdesk
- Quick Action and Equipment Turnaround

Equipment Monitoring and Control

Snag Load Protection (SLP)





AS A ONE STOP SUPPLIER,
SIBRE DELIVERS COMPREHENSIVE
SOLUTIONS FOR ALL DRIVES IN CRANES.

SERVICE-BRAKES



SAFETY-BRAKES



SNAG LOAD PROTECTION



STORM-BRAKES



WHEELS & SHEAVES



COUPLINGS



References



Maximize your operational efficacy caused by

- Increased operational safety
- Reduced maintenance requirements.
- Extended product life span.
- Better monitoring and control of equipment.



Sure to be Safe

Siegerland Bremsen

from conception to performance

Questions?

Visit us at booth 26!

